

# FASTTRAK

## Simple, Strong, Quick & Easy.

### ASSEMBLY INSTRUCTIONS

# WorkShop 1510

REVISION 11/15



W4535mm x D2800mm x H2085mm

### NOTES

BEFORE COMMENCING SHED ASSEMBLY, CHECK ALL PARTS. IF THERE IS A DISCREPANCY, PLEASE CALL YARDSAVER (SEE REAR OF INSTRUCTION BOOK)

DO NOT ASSEMBLE IN WINDY CONDITIONS



READ INSTRUCTIONS FIRST



3 PERSON ASSEMBLY



THE MANUFACTURERS CANNOT BE HELD RESPONSIBLE FOR ANY CONSEQUENCES DUE TO SHEDS THAT ARE NOT INSTALLED PER INSTRUCTIONS OR FOR DAMAGE DUE TO WEATHER CONDITIONS, ACTS OF GOD OR FOR SHEDS THAT ARE LEFT PARTIALLY ASSEMBLED OVERNIGHT. PARTS MAY CONTAIN SHARP EDGES & CORNERS. CARE MUST BE TAKEN WHEN HANDLING VARIOUS PIECES TO AVOID A MISHAP, FOR SAFETY SAKE, PLEASE USE A PAIR OF WORK GLOVES, EYE PROTECTION & PROTECTIVE CLOTHING WHEN ASSEMBLING OR PERFORMING ANY MAINTENANCE ON THE BUILDING.

Subject to changes © Spanbild Pty. Ltd.

## TOOLS REQUIRED

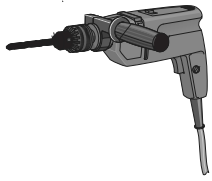

Electric Drill



Cordless Drill



Measuring Tape



Screwdrivers



8mm Masonry Drill Bit



6mm Drill Bit

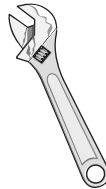

Shifting Spanner



Builders Pencil



Tin Snips  
(some models only)



Sturdy Ladder  
(two if possible)



Gloves



Protective Eyewear



Rubber Mallet

## HANDY HINTS FOR CONSTRUCTION

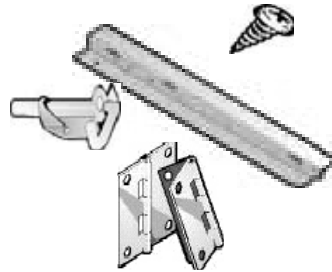
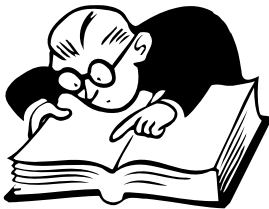

Read instructions and check parts carefully before assembling the shed.

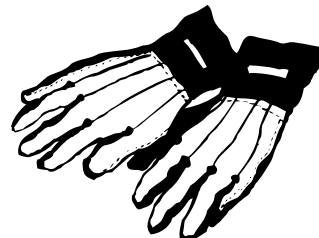

Please wear safety gloves and glasses at all times to protect against sharp metal edges.



Do not assemble in windy conditions as panels may be difficult to handle and damage may result.

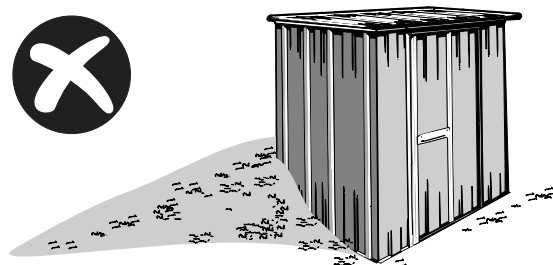

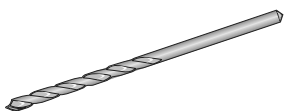

Do not back fill against the shed as this will result in corrosion. Allow drainage from the site.



MOST PILOT HOLES ARE PRE-PUNCHED AND IN THIS CASE DRILLING HOLES IS NOT NECESSARY, HOWEVER SOME PILOT HOLES NEED TO BE DRILLED WITH THE INCLUDED 2.5MM DRILL BIT WHERE INDICATED

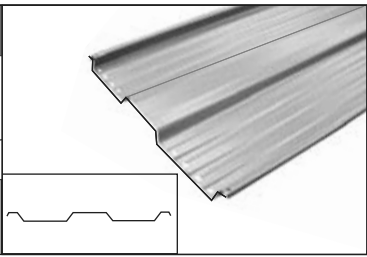
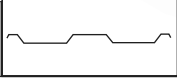
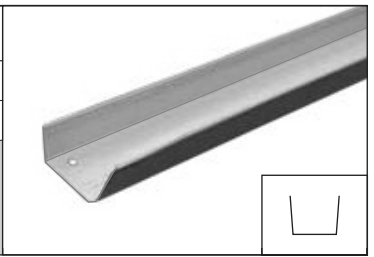
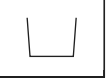
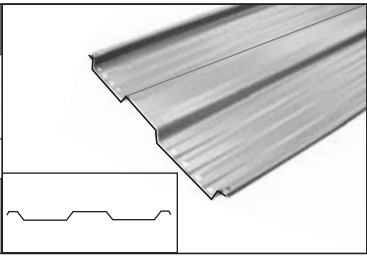
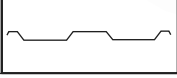
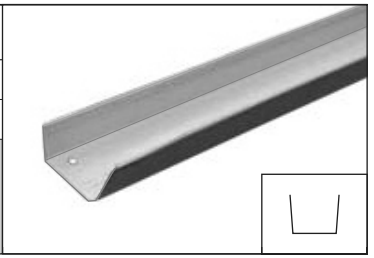
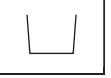
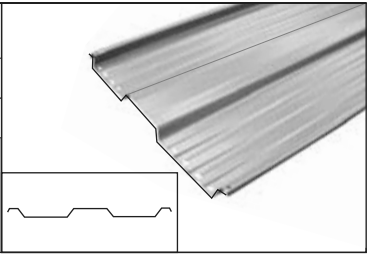
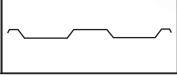
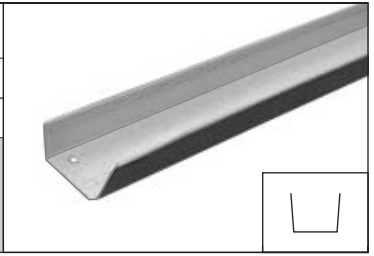
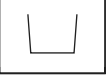
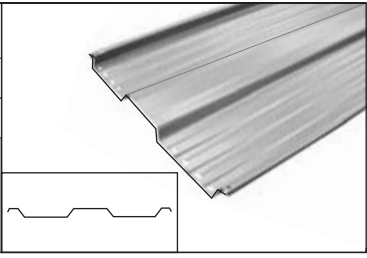
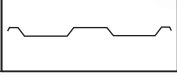
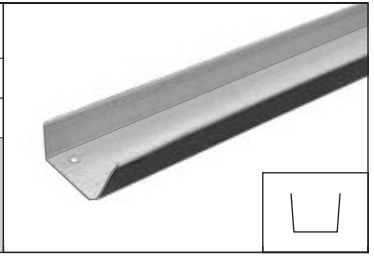
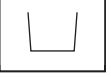
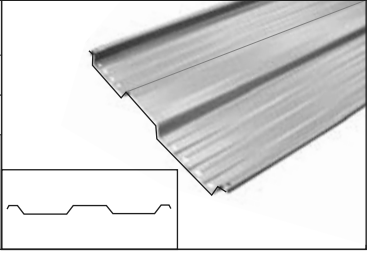
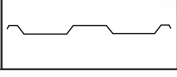
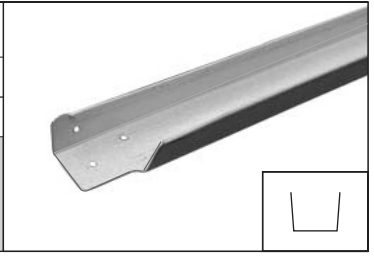
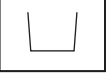
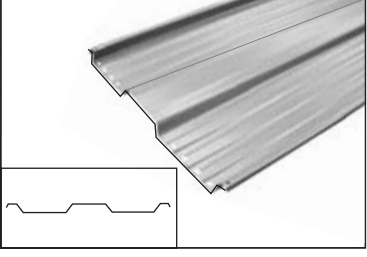
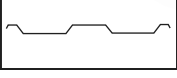
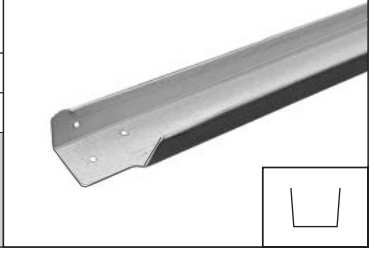
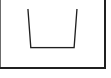
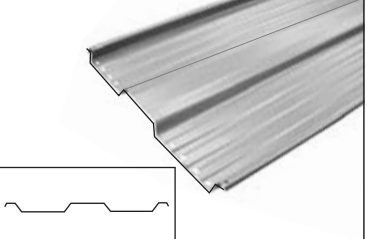
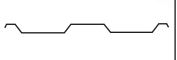

# PARTS LIST

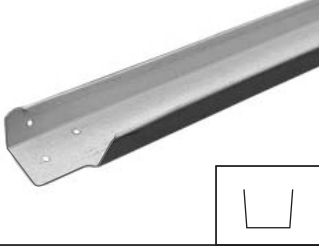
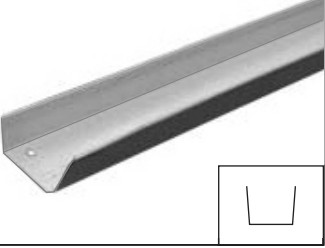
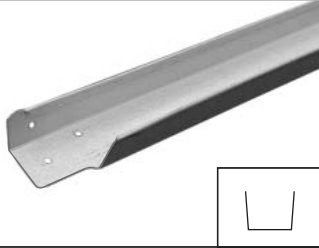
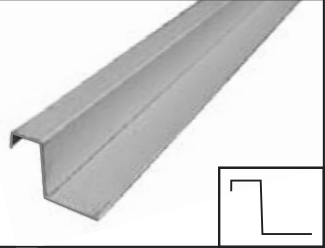
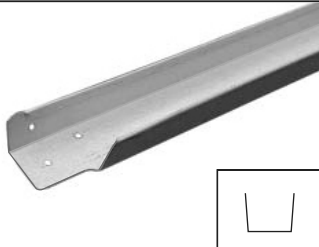
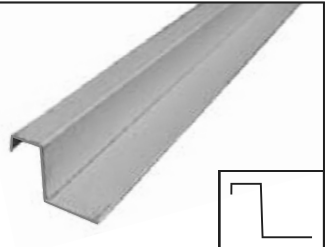
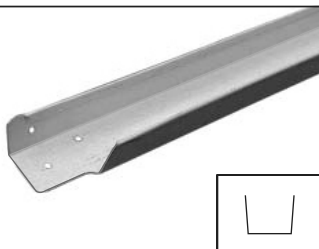
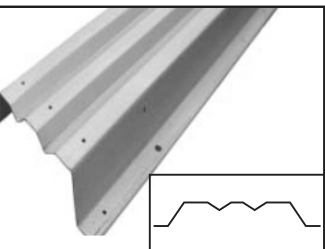
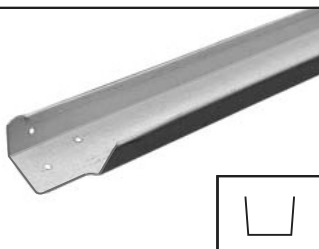
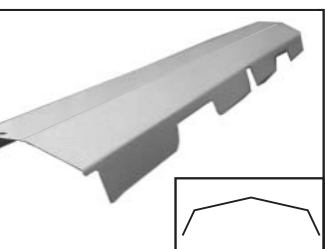
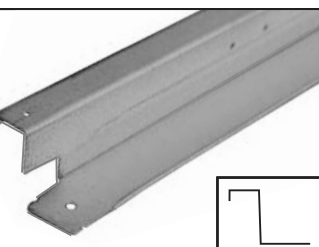
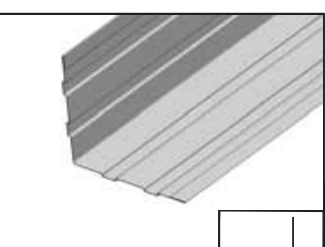
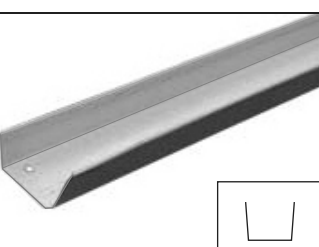
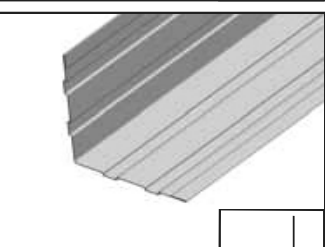

<table border="1"> <thead> <tr> <th colspan="3">PRODUCT NUMBERS</th> </tr> </thead> <tbody> <tr> <td>A1</td> <td>A2</td> <td>A3</td> </tr> <tr> <td>A4</td> <td>A5</td> <td>A6</td> </tr> <tr> <td>A7</td> <td>A8</td> <td></td> </tr> <tr> <td colspan="2">Quantity (total)</td> <td>8</td> </tr> <tr> <td colspan="3">Description: Gable Wall Panel</td> </tr> </tbody> </table>  	PRODUCT NUMBERS			A1	A2	A3	A4	A5	A6	A7	A8		Quantity (total)		8	Description: Gable Wall Panel			<table border="1"> <thead> <tr> <th>PRODUCT ID</th> <th>h</th> </tr> </thead> <tbody> <tr> <td>Length</td> <td>674mm</td> </tr> <tr> <td>Quantity</td> <td>4</td> </tr> <tr> <td colspan="2">Description: Door Frame Top/Bottom</td> </tr> </tbody> </table>  	PRODUCT ID	h	Length	674mm	Quantity	4	Description: Door Frame Top/Bottom	
PRODUCT NUMBERS																											
A1	A2	A3																									
A4	A5	A6																									
A7	A8																										
Quantity (total)		8																									
Description: Gable Wall Panel																											
PRODUCT ID	h																										
Length	674mm																										
Quantity	4																										
Description: Door Frame Top/Bottom																											
<table border="1"> <thead> <tr> <th colspan="3">PRODUCT NUMBERS</th> </tr> </thead> <tbody> <tr> <td>B1</td> <td>B2</td> <td>B3</td> </tr> <tr> <td>B4</td> <td>B5</td> <td>B6</td> </tr> <tr> <td>B7</td> <td>B8</td> <td></td> </tr> <tr> <td colspan="2">Quantity (total)</td> <td>8</td> </tr> <tr> <td colspan="3">Description: Gable Wall Panel</td> </tr> </tbody> </table>  	PRODUCT NUMBERS			B1	B2	B3	B4	B5	B6	B7	B8		Quantity (total)		8	Description: Gable Wall Panel			<table border="1"> <thead> <tr> <th>PRODUCT ID</th> <th>H</th> </tr> </thead> <tbody> <tr> <td>Length</td> <td>1008mm</td> </tr> <tr> <td>Quantity</td> <td>2</td> </tr> <tr> <td colspan="2">Description: Door Frame Top/Bottom</td> </tr> </tbody> </table>  	PRODUCT ID	H	Length	1008mm	Quantity	2	Description: Door Frame Top/Bottom	
PRODUCT NUMBERS																											
B1	B2	B3																									
B4	B5	B6																									
B7	B8																										
Quantity (total)		8																									
Description: Gable Wall Panel																											
PRODUCT ID	H																										
Length	1008mm																										
Quantity	2																										
Description: Door Frame Top/Bottom																											
<table border="1"> <thead> <tr> <th>PRODUCT ID</th> <th>C</th> </tr> </thead> <tbody> <tr> <td>Length</td> <td>1800mm</td> </tr> <tr> <td>Quantity</td> <td>16</td> </tr> <tr> <td colspan="2">Description: Wall Panel</td> </tr> </tbody> </table>  	PRODUCT ID	C	Length	1800mm	Quantity	16	Description: Wall Panel		<table border="1"> <thead> <tr> <th>PRODUCT ID</th> <th>I</th> </tr> </thead> <tbody> <tr> <td>Length</td> <td>1742mm</td> </tr> <tr> <td>Quantity</td> <td>6</td> </tr> <tr> <td colspan="2">Description: Door Frame Side</td> </tr> </tbody> </table>  	PRODUCT ID	I	Length	1742mm	Quantity	6	Description: Door Frame Side											
PRODUCT ID	C																										
Length	1800mm																										
Quantity	16																										
Description: Wall Panel																											
PRODUCT ID	I																										
Length	1742mm																										
Quantity	6																										
Description: Door Frame Side																											
<table border="1"> <thead> <tr> <th>PRODUCT ID</th> <th>D</th> </tr> </thead> <tbody> <tr> <td>Length</td> <td>1800mm</td> </tr> <tr> <td>Quantity</td> <td>3</td> </tr> <tr> <td colspan="2">Description: Wall Corner Panels</td> </tr> </tbody> </table>  	PRODUCT ID	D	Length	1800mm	Quantity	3	Description: Wall Corner Panels		<table border="1"> <thead> <tr> <th>PRODUCT ID</th> <th>J</th> </tr> </thead> <tbody> <tr> <td>Length</td> <td>1706mm</td> </tr> <tr> <td>Quantity</td> <td>6</td> </tr> <tr> <td colspan="2">Description: Door Boxing</td> </tr> </tbody> </table>  	PRODUCT ID	J	Length	1706mm	Quantity	6	Description: Door Boxing											
PRODUCT ID	D																										
Length	1800mm																										
Quantity	3																										
Description: Wall Corner Panels																											
PRODUCT ID	J																										
Length	1706mm																										
Quantity	6																										
Description: Door Boxing																											
<table border="1"> <thead> <tr> <th>PRODUCT ID</th> <th>E</th> </tr> </thead> <tbody> <tr> <td>Length</td> <td>1454mm</td> </tr> <tr> <td>Quantity</td> <td>26</td> </tr> <tr> <td colspan="2">Description: Roof Panels</td> </tr> </tbody> </table>  	PRODUCT ID	E	Length	1454mm	Quantity	26	Description: Roof Panels		<table border="1"> <thead> <tr> <th>PRODUCT ID</th> <th>k</th> </tr> </thead> <tbody> <tr> <td>Length</td> <td>1040mm</td> </tr> <tr> <td>Quantity</td> <td>4</td> </tr> <tr> <td colspan="2">Description: Door Bracing</td> </tr> </tbody> </table>  	PRODUCT ID	k	Length	1040mm	Quantity	4	Description: Door Bracing											
PRODUCT ID	E																										
Length	1454mm																										
Quantity	26																										
Description: Roof Panels																											
PRODUCT ID	k																										
Length	1040mm																										
Quantity	4																										
Description: Door Bracing																											
<table border="1"> <thead> <tr> <th>PRODUCT ID</th> <th>F</th> </tr> </thead> <tbody> <tr> <td>Length</td> <td>1738mm</td> </tr> <tr> <td>Quantity</td> <td>6</td> </tr> <tr> <td colspan="2">Description: Door Panel (Partially Slit)</td> </tr> </tbody> </table>  	PRODUCT ID	F	Length	1738mm	Quantity	6	Description: Door Panel (Partially Slit)		<table border="1"> <thead> <tr> <th>PRODUCT ID</th> <th>K</th> </tr> </thead> <tbody> <tr> <td>Length</td> <td>1280mm</td> </tr> <tr> <td>Quantity</td> <td>2</td> </tr> <tr> <td colspan="2">Description: Door Bracing</td> </tr> </tbody> </table>  	PRODUCT ID	K	Length	1280mm	Quantity	2	Description: Door Bracing											
PRODUCT ID	F																										
Length	1738mm																										
Quantity	6																										
Description: Door Panel (Partially Slit)																											
PRODUCT ID	K																										
Length	1280mm																										
Quantity	2																										
Description: Door Bracing																											
<table border="1"> <thead> <tr> <th>PRODUCT ID</th> <th>G</th> </tr> </thead> <tbody> <tr> <td>Length</td> <td>1738mm</td> </tr> <tr> <td>Quantity</td> <td>1</td> </tr> <tr> <td colspan="2">Description: Door Panel Centre</td> </tr> </tbody> </table>  	PRODUCT ID	G	Length	1738mm	Quantity	1	Description: Door Panel Centre		<table border="1"> <thead> <tr> <th>PRODUCT ID</th> <th>L</th> </tr> </thead> <tbody> <tr> <td>Length</td> <td>1706mm</td> </tr> <tr> <td>Quantity</td> <td>1</td> </tr> <tr> <td colspan="2">Description: Door Seal</td> </tr> </tbody> </table>  	PRODUCT ID	L	Length	1706mm	Quantity	1	Description: Door Seal											
PRODUCT ID	G																										
Length	1738mm																										
Quantity	1																										
Description: Door Panel Centre																											
PRODUCT ID	L																										
Length	1706mm																										
Quantity	1																										
Description: Door Seal																											

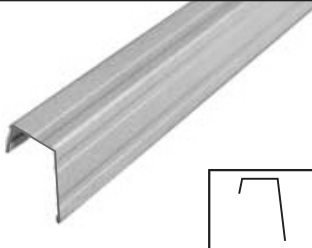

# PARTS LIST

<table border="1"> <tr> <td><b>PRODUCT ID</b></td> <td><b>M</b></td> </tr> <tr> <td><b>Length (spliced)</b></td> <td>2445mm =(1460 + 1115)</td> </tr> <tr> <td><b>Quantity</b></td> <td>(4 x 1460) + (4 x 1115)</td> </tr> <tr> <td colspan="2"><b>Description:</b> Top/Bottom Front/Rear Channel</td> </tr> </table>	<b>PRODUCT ID</b>	<b>M</b>	<b>Length (spliced)</b>	2445mm =(1460 + 1115)	<b>Quantity</b>	(4 x 1460) + (4 x 1115)	<b>Description:</b> Top/Bottom Front/Rear Channel			<table border="1"> <tr> <td><b>PRODUCT ID</b></td> <td><b>r</b></td> </tr> <tr> <td><b>Length</b></td> <td>1021mm</td> </tr> <tr> <td><b>Quantity</b></td> <td>1</td> </tr> <tr> <td colspan="2"><b>Description:</b> Bottom Door Spacer</td> </tr> </table>	<b>PRODUCT ID</b>	<b>r</b>	<b>Length</b>	1021mm	<b>Quantity</b>	1	<b>Description:</b> Bottom Door Spacer		
<b>PRODUCT ID</b>	<b>M</b>																		
<b>Length (spliced)</b>	2445mm =(1460 + 1115)																		
<b>Quantity</b>	(4 x 1460) + (4 x 1115)																		
<b>Description:</b> Top/Bottom Front/Rear Channel																			
<b>PRODUCT ID</b>	<b>r</b>																		
<b>Length</b>	1021mm																		
<b>Quantity</b>	1																		
<b>Description:</b> Bottom Door Spacer																			
<table border="1"> <tr> <td><b>PRODUCT ID</b></td> <td><b>m</b></td> </tr> <tr> <td><b>Length (spliced)</b></td> <td>2099mm</td> </tr> <tr> <td><b>Quantity</b></td> <td>4</td> </tr> <tr> <td colspan="2"><b>Description:</b> Top/Bottom Front/Rear Channel</td> </tr> </table>	<b>PRODUCT ID</b>	<b>m</b>	<b>Length (spliced)</b>	2099mm	<b>Quantity</b>	4	<b>Description:</b> Top/Bottom Front/Rear Channel			<table border="1"> <tr> <td><b>PRODUCT ID</b></td> <td><b>S</b></td> </tr> <tr> <td><b>Length</b></td> <td>1367mm</td> </tr> <tr> <td><b>Quantity</b></td> <td>1</td> </tr> <tr> <td colspan="2"><b>Description:</b> Top Door Spacer</td> </tr> </table>	<b>PRODUCT ID</b>	<b>S</b>	<b>Length</b>	1367mm	<b>Quantity</b>	1	<b>Description:</b> Top Door Spacer		
<b>PRODUCT ID</b>	<b>m</b>																		
<b>Length (spliced)</b>	2099mm																		
<b>Quantity</b>	4																		
<b>Description:</b> Top/Bottom Front/Rear Channel																			
<b>PRODUCT ID</b>	<b>S</b>																		
<b>Length</b>	1367mm																		
<b>Quantity</b>	1																		
<b>Description:</b> Top Door Spacer																			
<table border="1"> <tr> <td><b>PRODUCT ID</b></td> <td><b>N</b></td> </tr> <tr> <td><b>Length (spliced)</b></td> <td>2791mm =(1461 + 1460)</td> </tr> <tr> <td><b>Quantity</b></td> <td>(2 x 1461) + (2 x 1460)</td> </tr> <tr> <td colspan="2"><b>Description:</b> Side Channel Gable Bottom</td> </tr> </table>	<b>PRODUCT ID</b>	<b>N</b>	<b>Length (spliced)</b>	2791mm =(1461 + 1460)	<b>Quantity</b>	(2 x 1461) + (2 x 1460)	<b>Description:</b> Side Channel Gable Bottom			<table border="1"> <tr> <td><b>PRODUCT ID</b></td> <td><b>S1</b></td> </tr> <tr> <td><b>Length</b></td> <td>1021mm</td> </tr> <tr> <td><b>Quantity</b></td> <td>1</td> </tr> <tr> <td colspan="2"><b>Description:</b> Top Door Spacer</td> </tr> </table>	<b>PRODUCT ID</b>	<b>S1</b>	<b>Length</b>	1021mm	<b>Quantity</b>	1	<b>Description:</b> Top Door Spacer		
<b>PRODUCT ID</b>	<b>N</b>																		
<b>Length (spliced)</b>	2791mm =(1461 + 1460)																		
<b>Quantity</b>	(2 x 1461) + (2 x 1460)																		
<b>Description:</b> Side Channel Gable Bottom																			
<b>PRODUCT ID</b>	<b>S1</b>																		
<b>Length</b>	1021mm																		
<b>Quantity</b>	1																		
<b>Description:</b> Top Door Spacer																			
<table border="1"> <tr> <td><b>PRODUCT ID</b></td> <td><b>O</b></td> </tr> <tr> <td><b>Length</b></td> <td>1411mm</td> </tr> <tr> <td><b>Quantity</b></td> <td>2</td> </tr> <tr> <td colspan="2"><b>Description:</b> Side Channel Gable Top</td> </tr> </table>	<b>PRODUCT ID</b>	<b>O</b>	<b>Length</b>	1411mm	<b>Quantity</b>	2	<b>Description:</b> Side Channel Gable Top			<table border="1"> <tr> <td><b>PRODUCT ID</b></td> <td><b>T</b></td> </tr> <tr> <td><b>Length</b></td> <td>1364mm</td> </tr> <tr> <td><b>Quantity</b></td> <td>8</td> </tr> <tr> <td colspan="2"><b>Description:</b> Ridge Beam</td> </tr> </table>	<b>PRODUCT ID</b>	<b>T</b>	<b>Length</b>	1364mm	<b>Quantity</b>	8	<b>Description:</b> Ridge Beam		
<b>PRODUCT ID</b>	<b>O</b>																		
<b>Length</b>	1411mm																		
<b>Quantity</b>	2																		
<b>Description:</b> Side Channel Gable Top																			
<b>PRODUCT ID</b>	<b>T</b>																		
<b>Length</b>	1364mm																		
<b>Quantity</b>	8																		
<b>Description:</b> Ridge Beam																			
<table border="1"> <tr> <td><b>PRODUCT ID</b></td> <td><b>P</b></td> </tr> <tr> <td><b>Length</b></td> <td>1415mm</td> </tr> <tr> <td><b>Quantity</b></td> <td>2</td> </tr> <tr> <td colspan="2"><b>Description:</b> Side Channel Gable Top</td> </tr> </table>	<b>PRODUCT ID</b>	<b>P</b>	<b>Length</b>	1415mm	<b>Quantity</b>	2	<b>Description:</b> Side Channel Gable Top			<table border="1"> <tr> <td><b>PRODUCT ID</b></td> <td><b>U</b></td> </tr> <tr> <td><b>Length</b></td> <td>708mm</td> </tr> <tr> <td><b>Quantity</b></td> <td>7</td> </tr> <tr> <td colspan="2"><b>Description:</b> Ridge Cap</td> </tr> </table>	<b>PRODUCT ID</b>	<b>U</b>	<b>Length</b>	708mm	<b>Quantity</b>	7	<b>Description:</b> Ridge Cap		
<b>PRODUCT ID</b>	<b>P</b>																		
<b>Length</b>	1415mm																		
<b>Quantity</b>	2																		
<b>Description:</b> Side Channel Gable Top																			
<b>PRODUCT ID</b>	<b>U</b>																		
<b>Length</b>	708mm																		
<b>Quantity</b>	7																		
<b>Description:</b> Ridge Cap																			
<table border="1"> <tr> <td><b>PRODUCT ID</b></td> <td><b>Q</b></td> </tr> <tr> <td><b>Length</b></td> <td>1800mm</td> </tr> <tr> <td><b>Quantity</b></td> <td>4</td> </tr> <tr> <td colspan="2"><b>Description:</b> Door Jamb</td> </tr> </table>	<b>PRODUCT ID</b>	<b>Q</b>	<b>Length</b>	1800mm	<b>Quantity</b>	4	<b>Description:</b> Door Jamb			<table border="1"> <tr> <td><b>PRODUCT ID</b></td> <td><b>V</b></td> </tr> <tr> <td><b>Length</b></td> <td>1750mm</td> </tr> <tr> <td><b>Quantity</b></td> <td>4</td> </tr> <tr> <td colspan="2"><b>Description:</b> Gutter Trim</td> </tr> </table>	<b>PRODUCT ID</b>	<b>V</b>	<b>Length</b>	1750mm	<b>Quantity</b>	4	<b>Description:</b> Gutter Trim		
<b>PRODUCT ID</b>	<b>Q</b>																		
<b>Length</b>	1800mm																		
<b>Quantity</b>	4																		
<b>Description:</b> Door Jamb																			
<b>PRODUCT ID</b>	<b>V</b>																		
<b>Length</b>	1750mm																		
<b>Quantity</b>	4																		
<b>Description:</b> Gutter Trim																			
<table border="1"> <tr> <td><b>PRODUCT ID</b></td> <td><b>R</b></td> </tr> <tr> <td><b>Length</b></td> <td>1367mm</td> </tr> <tr> <td><b>Quantity</b></td> <td>1</td> </tr> <tr> <td colspan="2"><b>Description:</b> Bottom Door Spacer</td> </tr> </table>	<b>PRODUCT ID</b>	<b>R</b>	<b>Length</b>	1367mm	<b>Quantity</b>	1	<b>Description:</b> Bottom Door Spacer			<table border="1"> <tr> <td><b>PRODUCT ID</b></td> <td><b>V1</b></td> </tr> <tr> <td><b>Length</b></td> <td>1058mm</td> </tr> <tr> <td><b>Quantity</b></td> <td>2</td> </tr> <tr> <td colspan="2"><b>Description:</b> Gutter Trim</td> </tr> </table>	<b>PRODUCT ID</b>	<b>V1</b>	<b>Length</b>	1058mm	<b>Quantity</b>	2	<b>Description:</b> Gutter Trim		
<b>PRODUCT ID</b>	<b>R</b>																		
<b>Length</b>	1367mm																		
<b>Quantity</b>	1																		
<b>Description:</b> Bottom Door Spacer																			
<b>PRODUCT ID</b>	<b>V1</b>																		
<b>Length</b>	1058mm																		
<b>Quantity</b>	2																		
<b>Description:</b> Gutter Trim																			

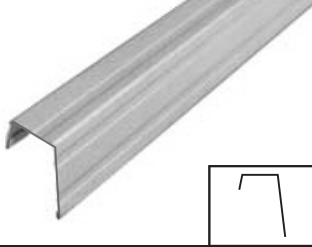

# PARTS LIST

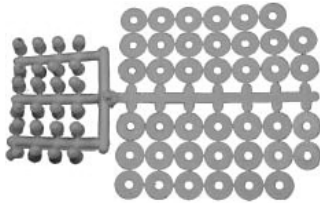

<b>PRODUCT ID</b>	<b>W</b>		<b>Quantity</b>	<b>16</b>	
<b>Length</b>	1446mm		<b>Description:</b>	Nut & Bolt 3/16"	
<b>Quantity</b>	2				
<b>Description:</b> Roof Angle Trim					

<b>PRODUCT ID</b>	<b>W1</b>		<b>Quantity</b>	<b>2</b>	
<b>Length</b>	1443mm		<b>Description:</b>	Ridge Beam Bracket	
<b>Quantity</b>	2				
<b>Description:</b> Roof Angle Trim					

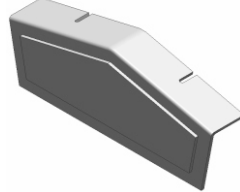
<b>Quantity</b>	<b>3</b>		<b>Quantity</b>	<b>12</b>	
<b>Description:</b> Plastic Washer and Screw Cap Sheet			<b>Description:</b>	Masonry Anchor	

<b>Quantity</b>	<b>4</b>		<b>Quantity</b>	<b>2</b>	
<b>Description:</b> Plastic Corner Cap			<b>Description:</b>	Door Plate	

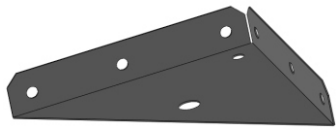
<b>Quantity</b>	<b>2</b>		<b>Quantity</b>	<b>5</b>	
<b>Description:</b> Plastic Ridge End Cap			<b>Description:</b>	Clip Nut	

<b>Quantity</b>	<b>8</b>		<b>Quantity</b>	<b>1</b>	
<b>Description:</b> Corner Bracket			<b>Description:</b>	Phillips Head Bit	

<b>Quantity</b>	<b>16</b>		<b>Quantity</b>	<b>600</b>	
<b>Description:</b> 55mm Bracket			<b>Description:</b>	Self Tapping Screws - Silver	

# PARTS LIST

<b>Quantity</b>	1	
<b>Description:</b>		
2.5mm Drill Bit		

<b>Quantity</b>	4	
<b>Description:</b>		
Padbolt		

<b>Quantity</b>	6	
<b>Description:</b>		
Hinges (offset)		

<b>Quantity</b>	4	
<b>Description:</b>		
Keeper		

# PORTAL FRAME - PARTS LIST

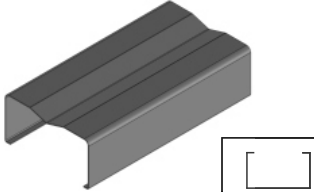
<b>PRODUCT ID</b>	<b>A</b>	
<b>Length (spliced)</b>	1725mm	
<b>Quantity</b>	4	
<b>Description:</b> Portal Leg		

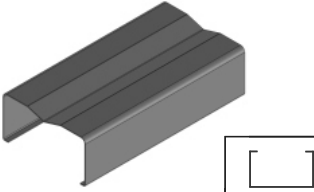
<b>PRODUCT ID</b>	<b>C</b>	
<b>Length</b>	1820mm	
<b>Quantity</b>	2	
<b>Description:</b> Top Gusset		

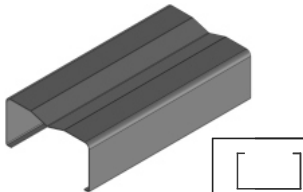
<b>PRODUCT ID</b>	<b>B</b>	
<b>Length (spliced)</b>	1355mm	
<b>Quantity</b>	4	
<b>Description:</b> Roof Beam		

<b>PRODUCT ID</b>	<b>D</b>	
<b>Length</b>	810mm	
<b>Quantity</b>	4	
<b>Description:</b> Corner Gusset		

<b>Quantity</b>	4	
<b>Description:</b>		
70x100 Plate		

<b>Quantity</b>	2	
<b>Description:</b>		
Gable Gusset Strap		

<b>Quantity</b>	126	
<b>Description:</b>		
Self Drilling Tek Screw (Portal)		

<b>PRODUCT ID</b>	<b>X</b>	
<b>Length (spliced)</b>	2710mm =(1461 + 1460)	
<b>Quantity</b>	(2 x 1461) + (2 x 1460)	
<b>Description:</b> Bracing channel		

<b>Quantity</b>	1	
<b>Description:</b>		
Nut Runner		

# FOUNDATION

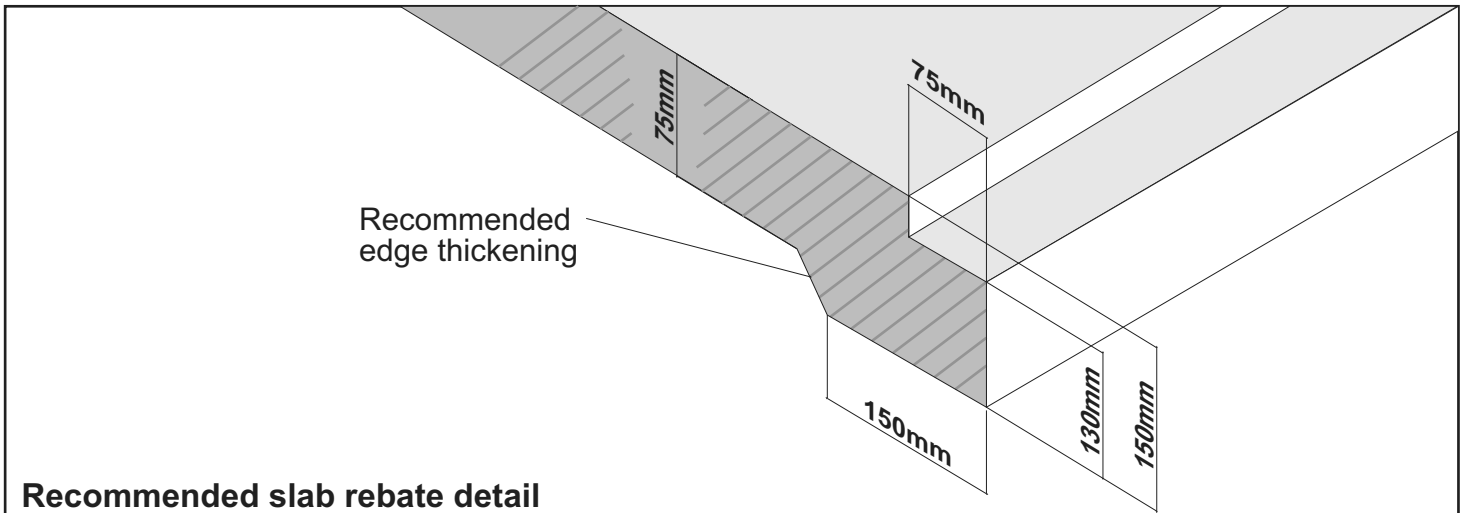

## Recommended slab rebate detail

Although *not required*, it is strongly recommended that, to avoid water leakage around the base of your shed, a rebate be cast into the slab. This will allow the shed to sit below the slab level and prevent water from reaching the upper level of the slab.

If you planning a rebated slab make sure to cut the 4 corners at  $125 \times 45$  as shown in detail below. Also cut short the length of the portal leg by 20mm.

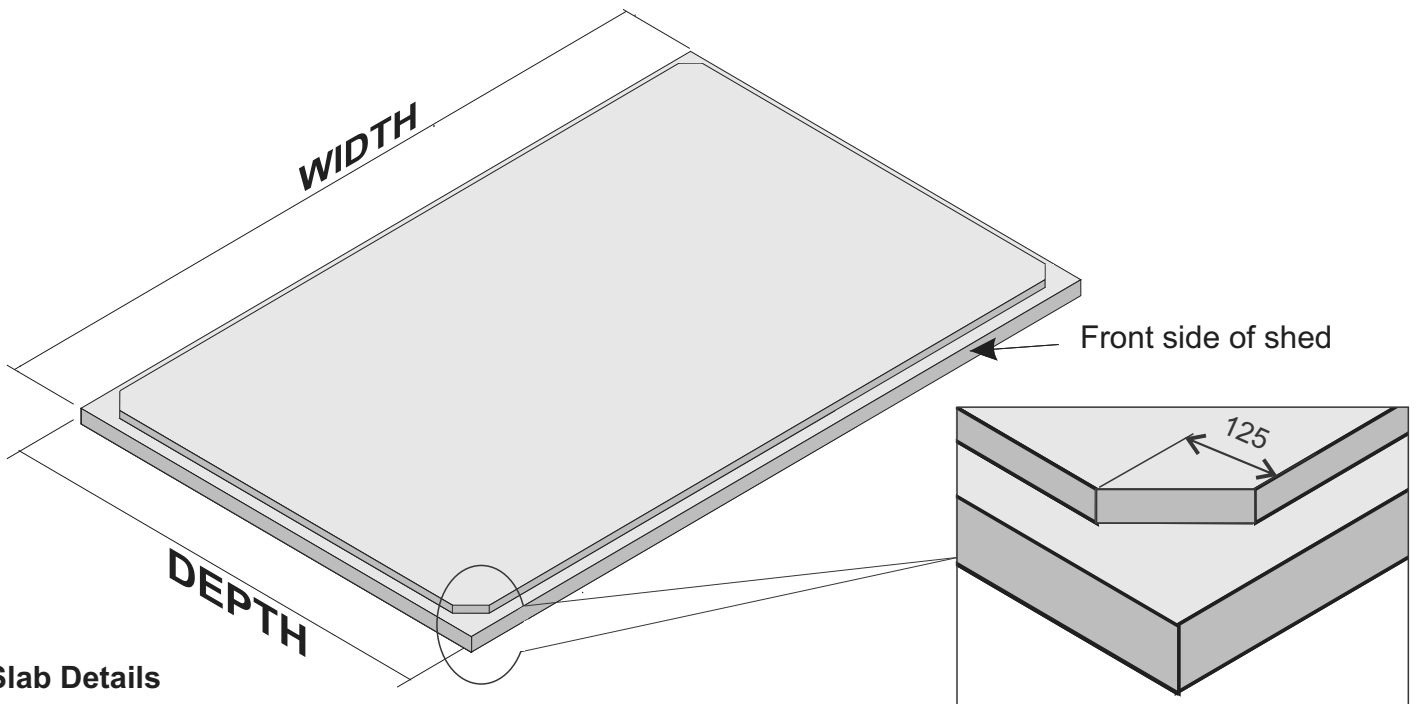

## Slab Details

Your garden shed must be erected on a solid, level and square foundation. We strongly recommend you pour a concrete slab 75mm thick, reinforced with SL62 mesh (minimum) using dimensions from the table below.

**\*Masonry anchors are supplied\***

SHED CODE	OUTER SLAB SIZE width x depth	ANCHORS M8 x 40mm
<b>WS 1510</b>	<b>4635mm x 2900mm</b>	<b>12</b>

# PORTAL FRAME ASSEMBLY

1

Mark out with pencil or chalk on the flat ground as shown

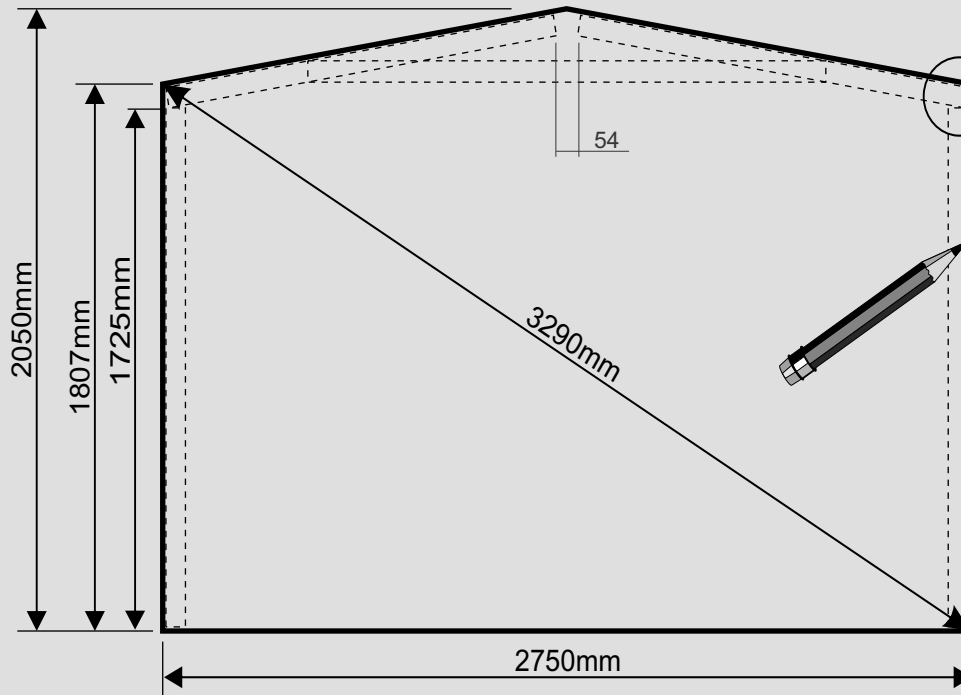

Roof beam sits on top of leg



2

All four Portal Legs are required to be boxed as shown to make 2 legs

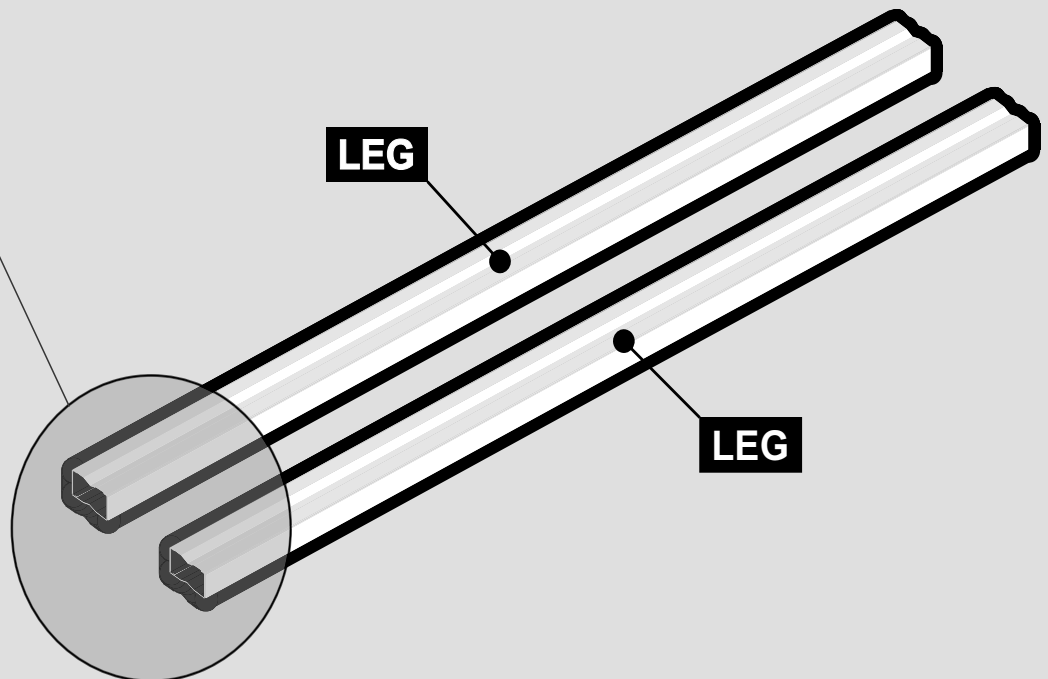
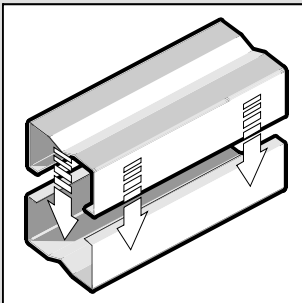

Make sure to cut 20mm (L= 1708) off, if you have a rebated slab.

# PORTAL FRAME ASSEMBLY

3

Screw the boxed legs together using the Tek Screws (portal)  
Use bracing channel "X" to temporarily hold it in place.  
Join the bracing channels to the length of 2710mm.

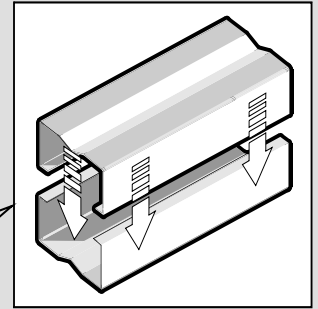

All four Roof Beams are required to be boxed as shown

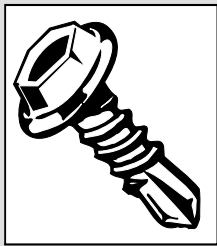
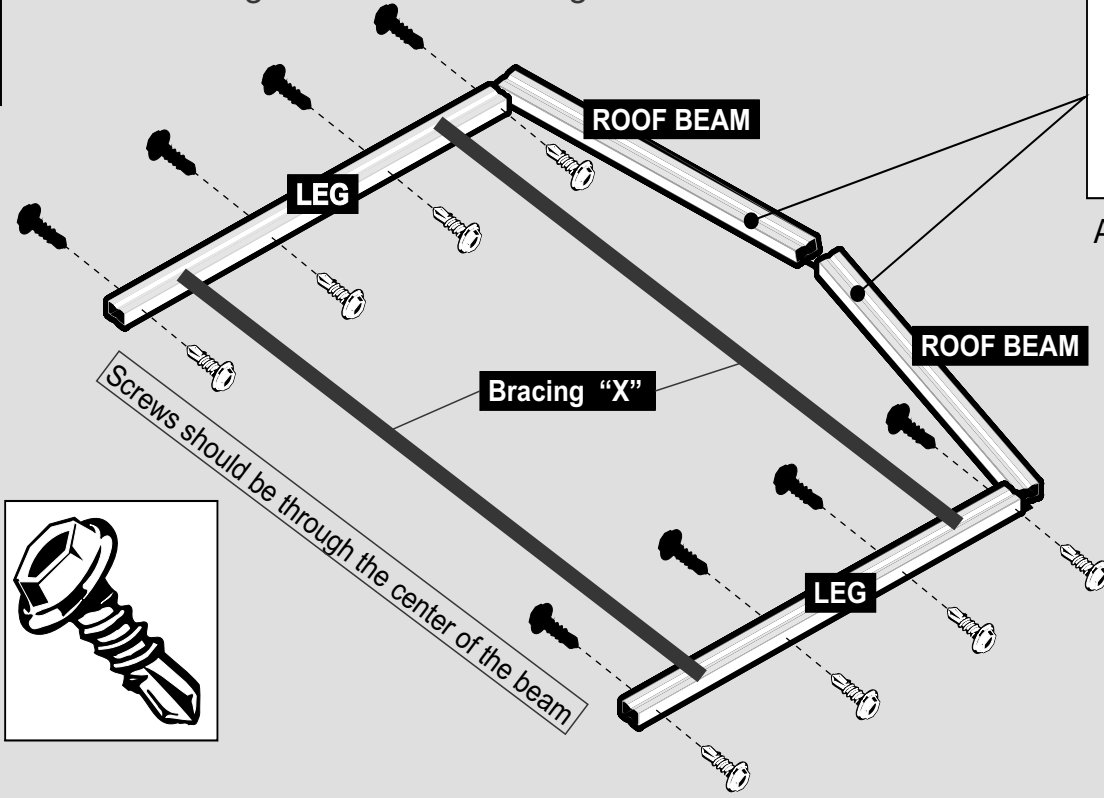

4

Screw the boxed roof beams together using the Tek Screws (portal)

Screws should be through the center of the beam

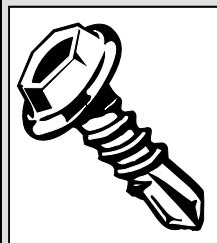
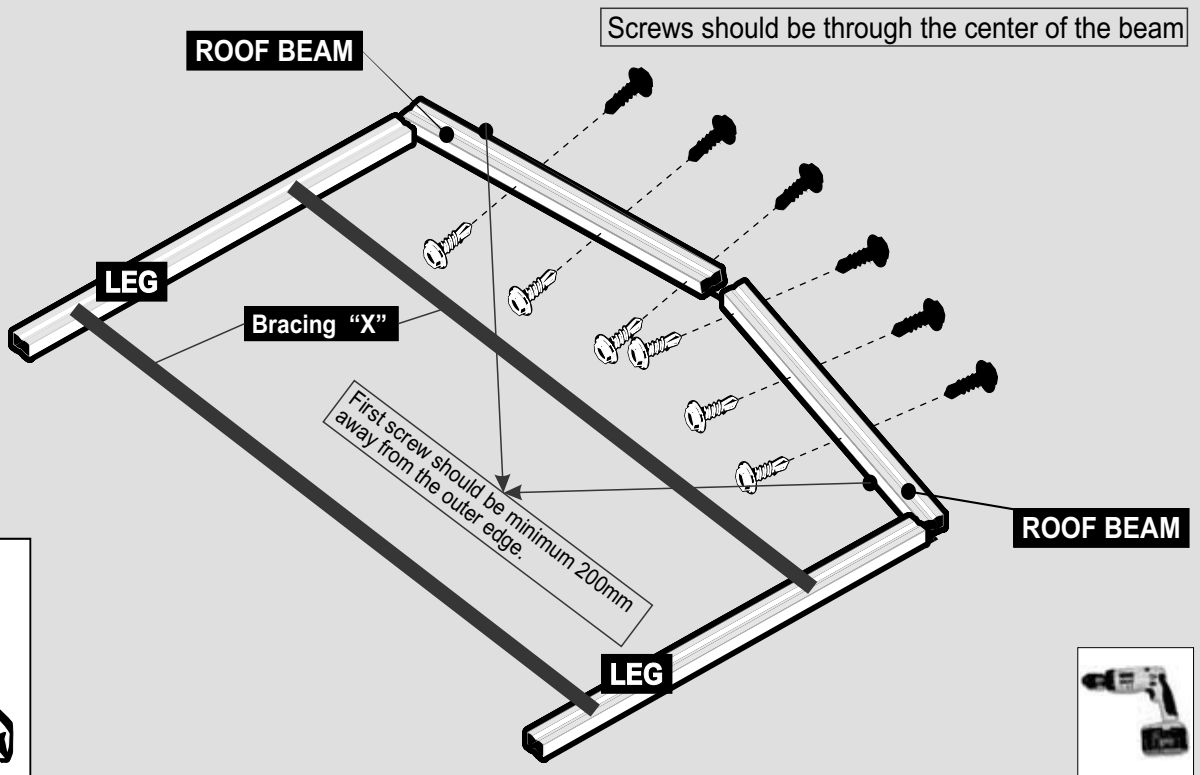

# PORTAL FRAME ASSEMBLY

Assemble, lay beams out as shown and fix first side of portal

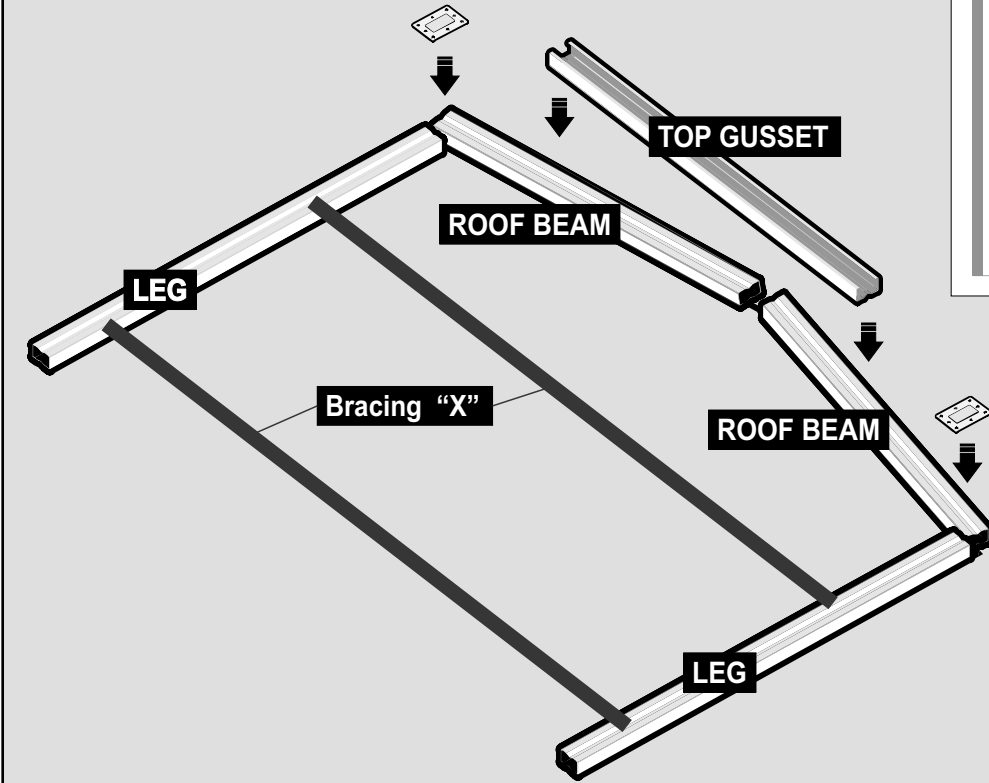

5

Attach the Roof Beams to the Legs using the 100x70 Plate

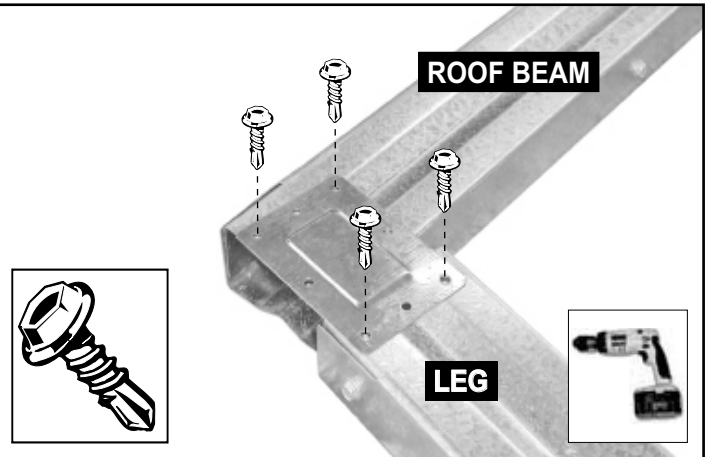
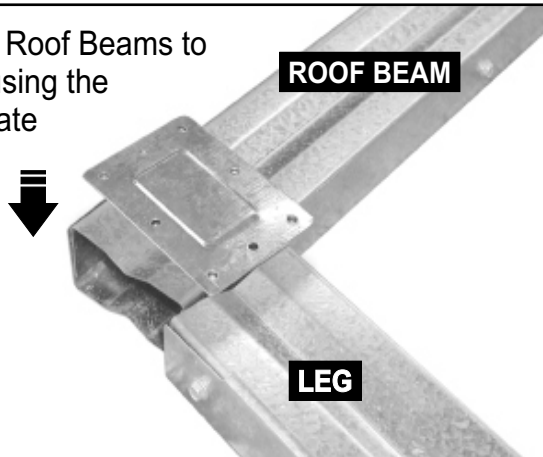

6

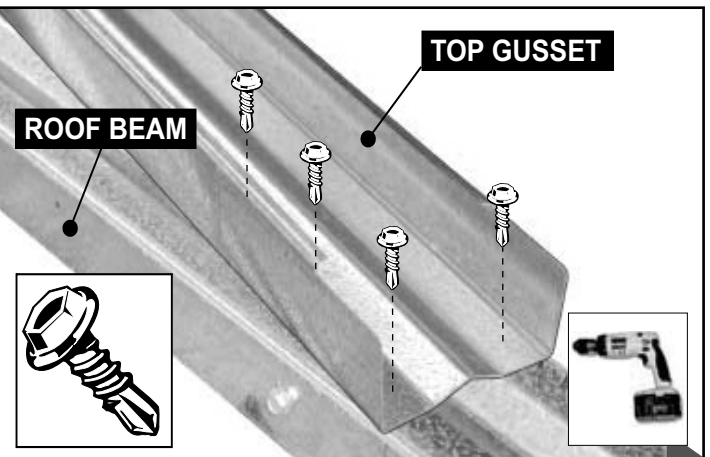
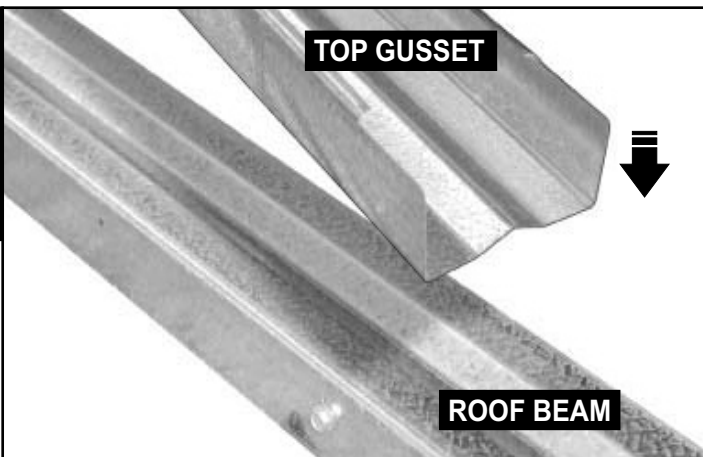

# PORTAL FRAME ASSEMBLY

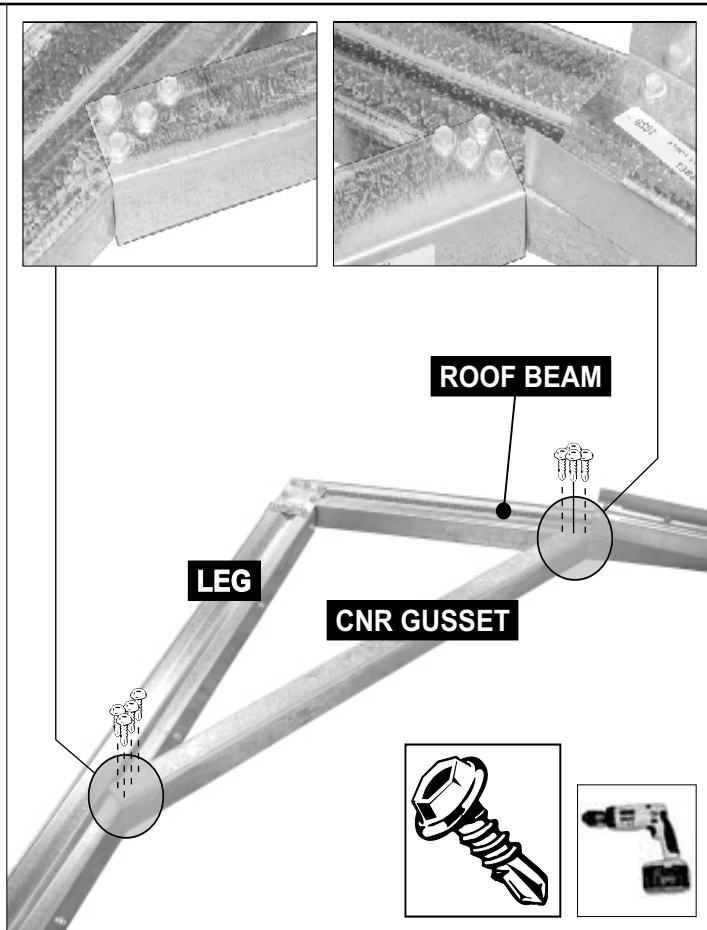
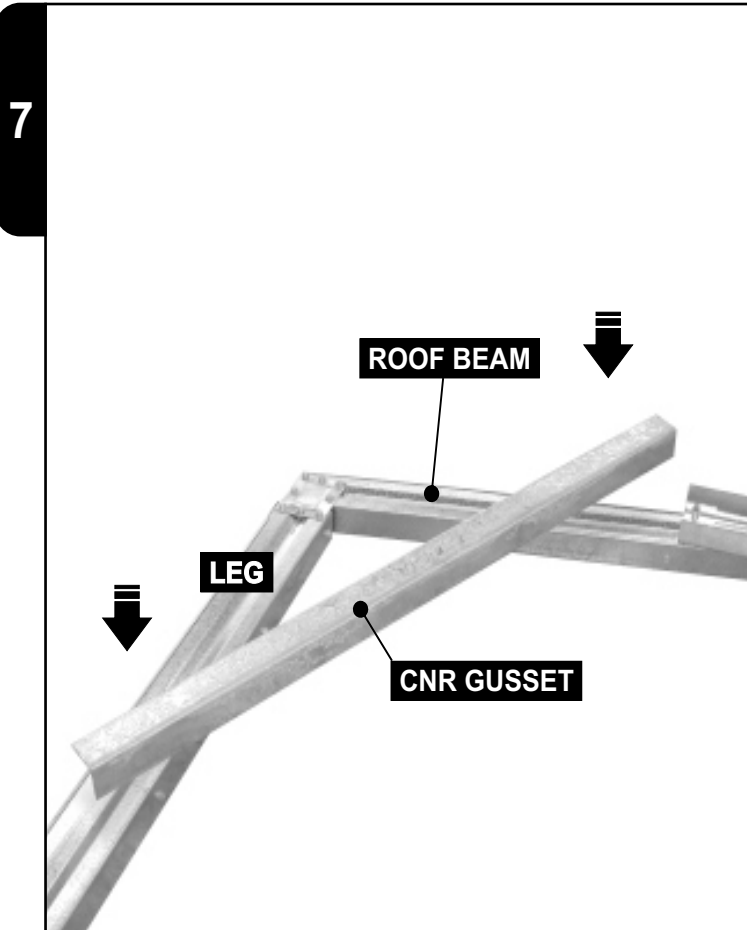
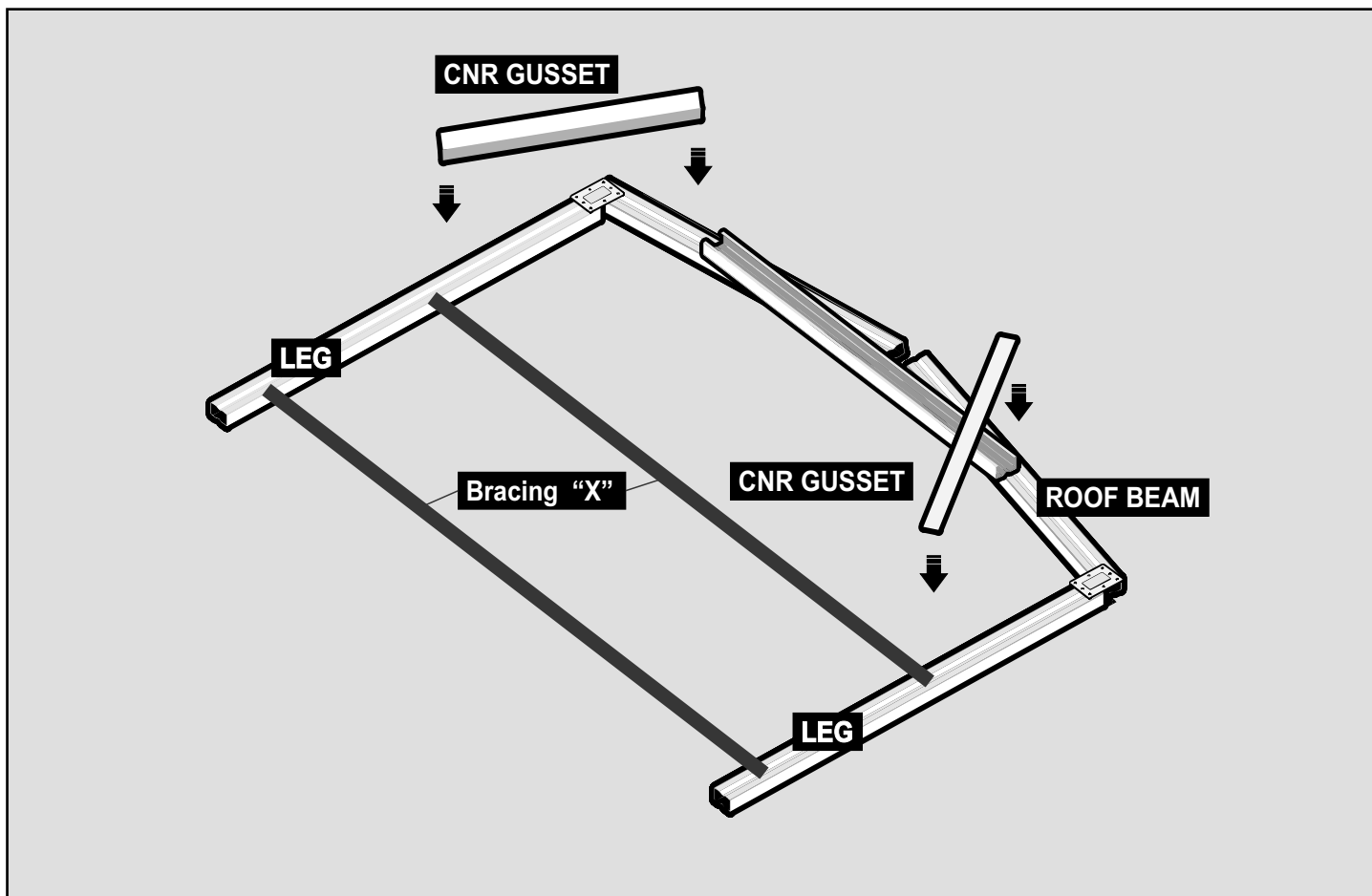

# PORTAL FRAME ASSEMBLY

8

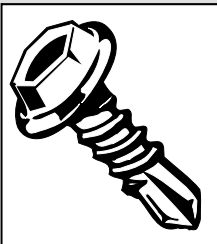
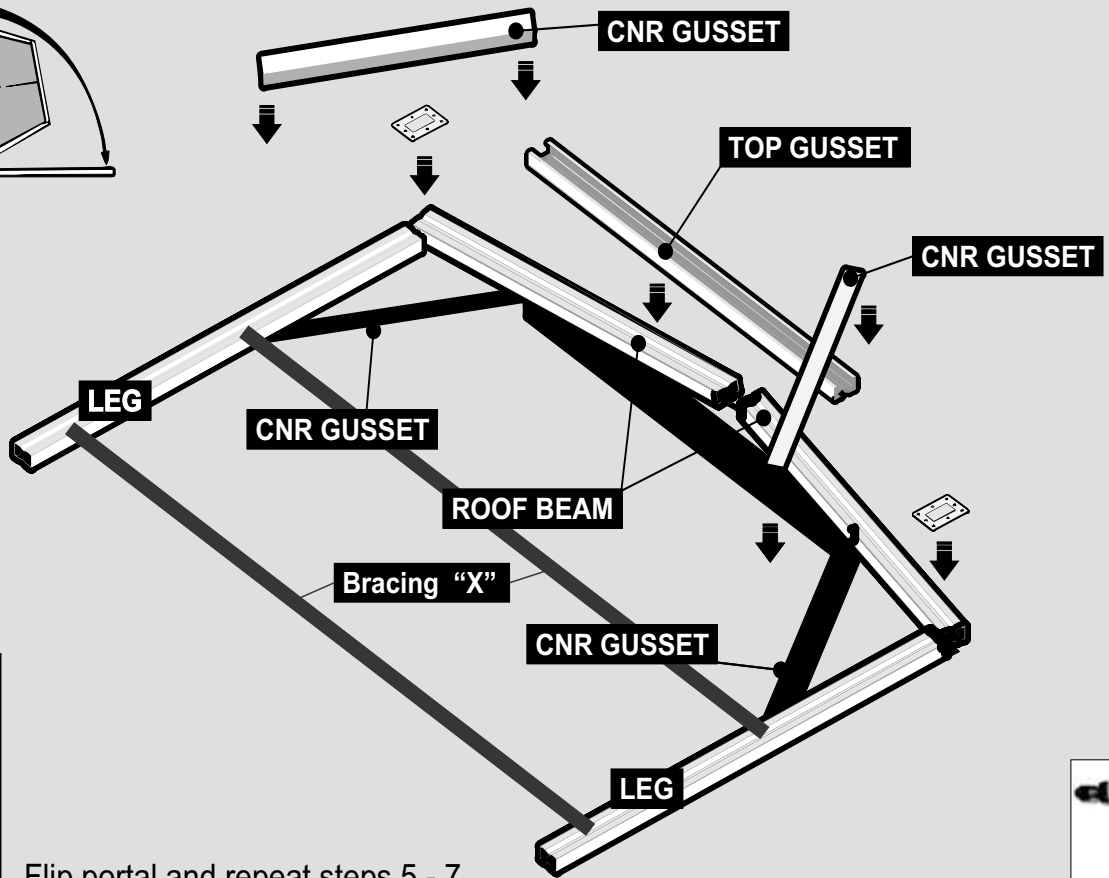
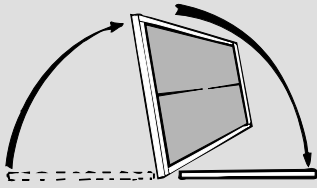

Flip portal and repeat steps 5 - 7



9

Join both sides of the Corner Gussets using the Portal Tek Screws, then remove the top bracing "X".

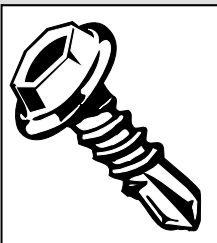
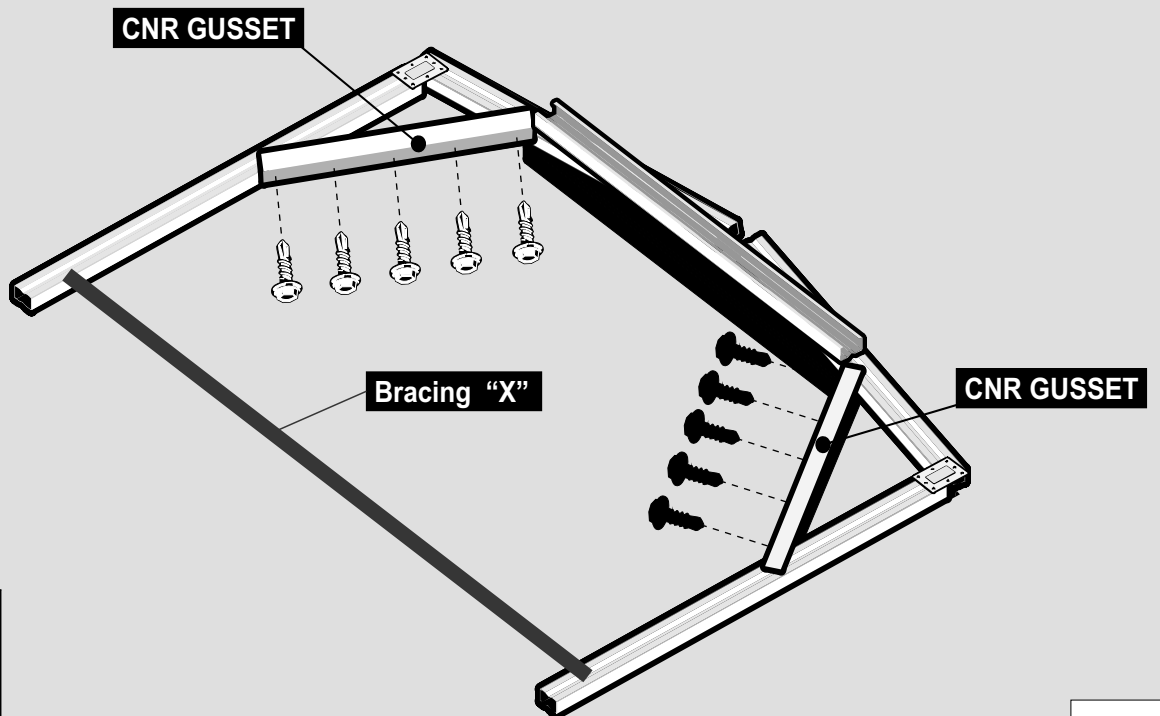

## PORTAL FRAME ASSEMBLY

Stand up the portal frame and position as per the dimension given here. Make sure the distance 2490 from the 2x2 Panel Door side edge of the slab. Portal frame sit 75mm inside the width of the slab over the edge the edge. It is possible to inter change the position of this door (left or right).

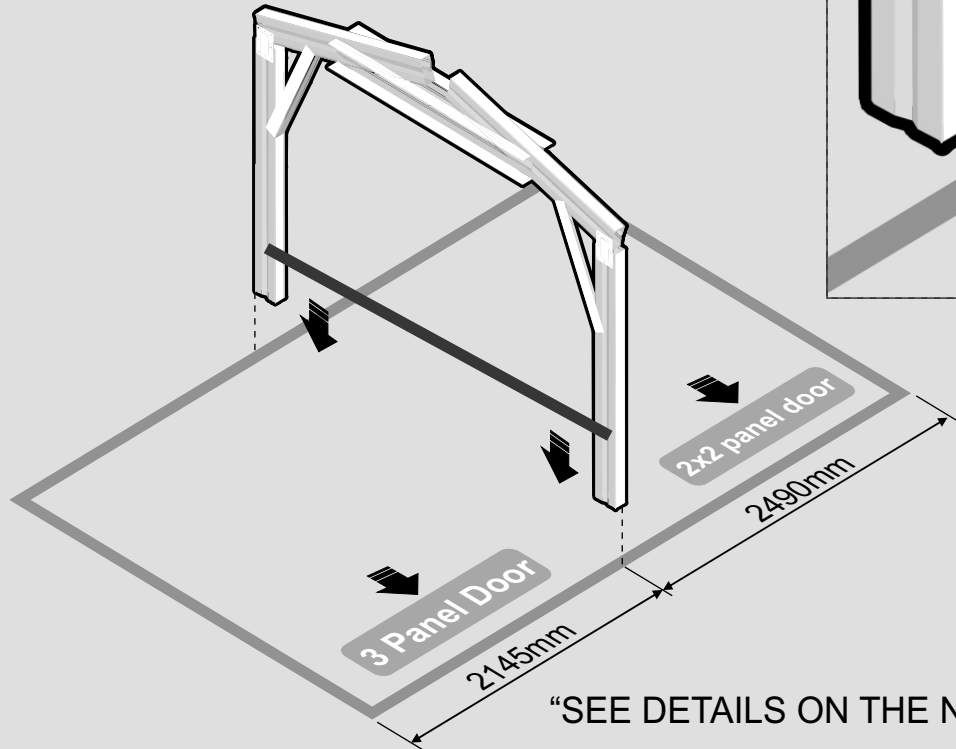

Make sure the portals stood up properly on the slab. Out of square portal fixing may create hassle later while panel fixing.

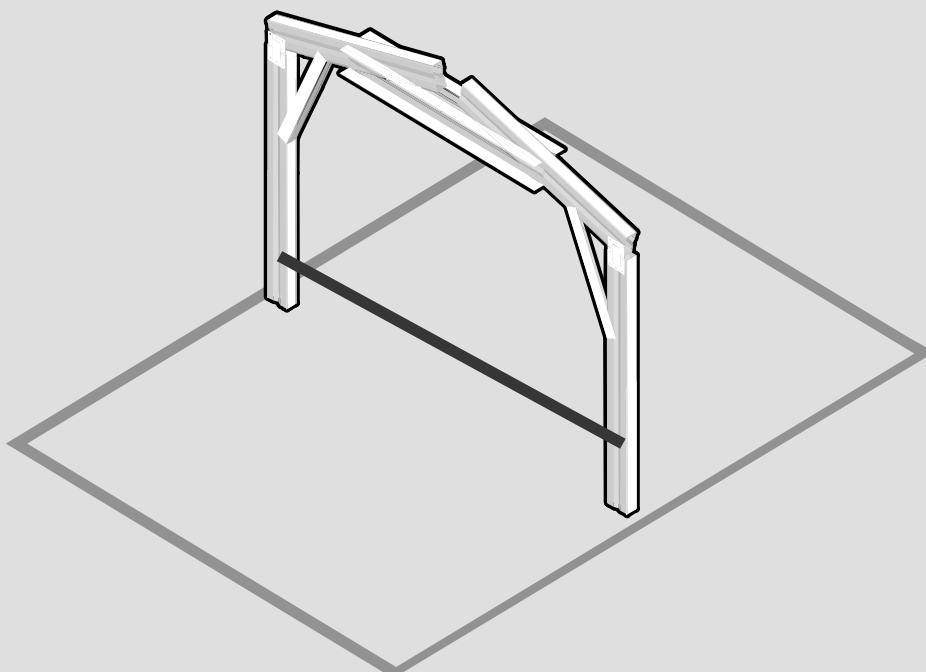

## PORTAL FRAME ASSEMBLY

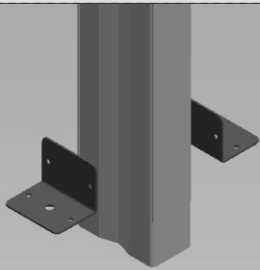

Place the 55mm Bracket as shown then fix it to the portal leg. Make sure it is square and flat to the slab.

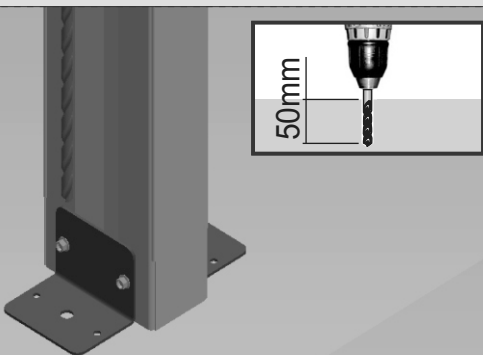
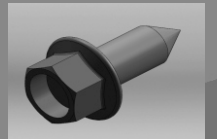
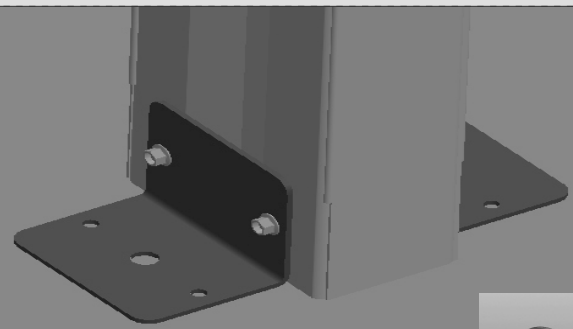

Now Pre drill the Dia 8mm hole to a depth of 50mm.

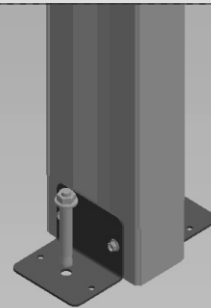

Insert and tighten the masonry anchor on all 4 brackets.

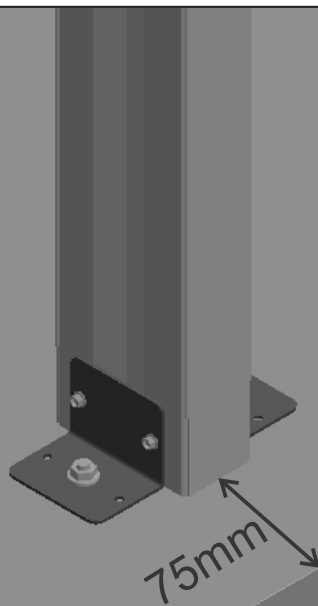

Now can remove the bracing channel "X".

# REAR WALL PANEL

Required to manipulate sheeting panel to align the channel holes

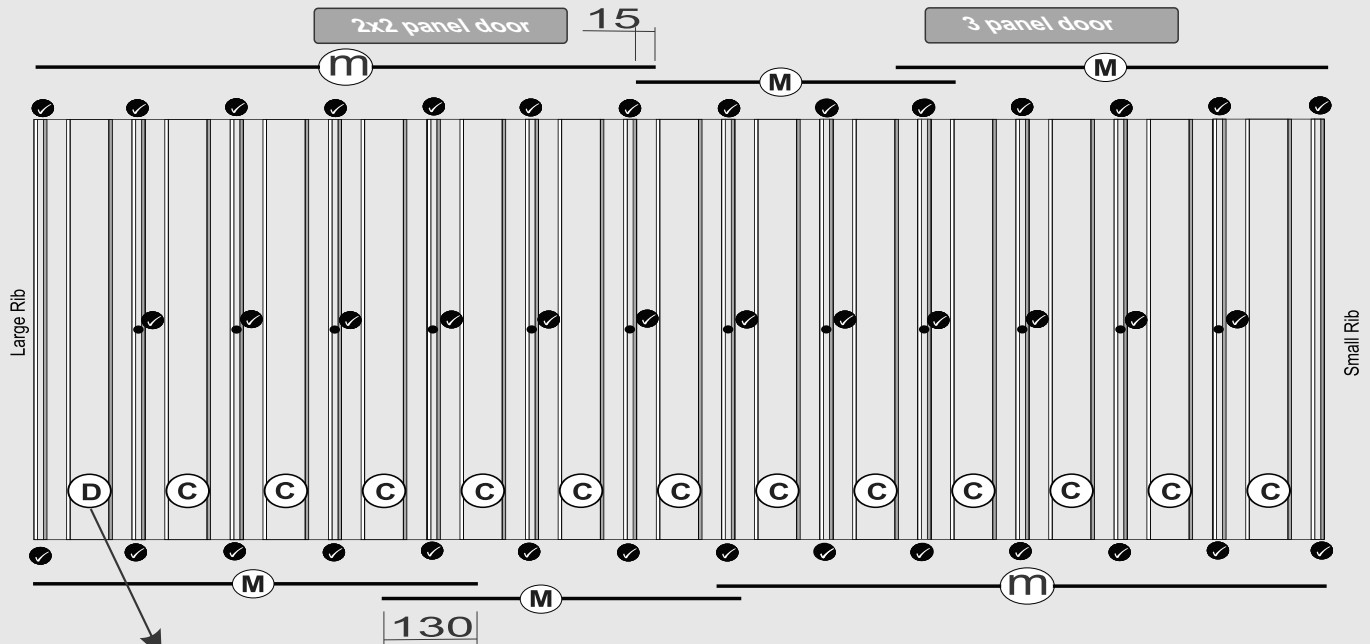

“D” - Wall Corner Panel

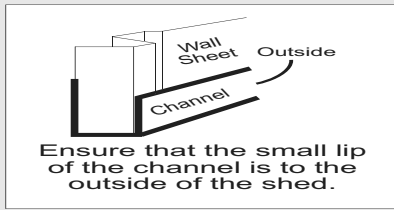

Overlap top and bottom channel by 130mm & 15mm. Fit the top and bottom channel to the wall panels. Ensure the holes in the channels are in line with holes in the rib of the sheeting and the small flange on the channel positioned outside face of the sheeting. 130mm overlap should be positioned on the 2x2 panel door side. It is possible to interchange door position(left and right).

1

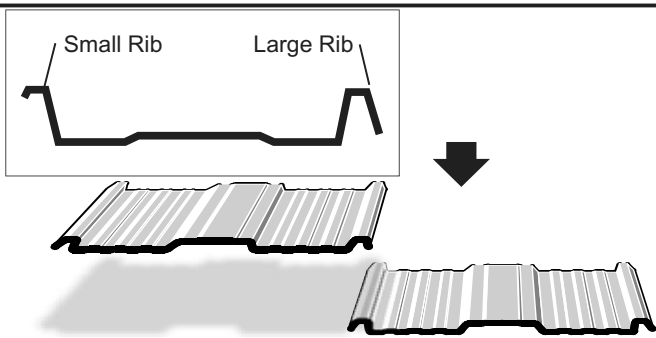

Lay the wall panels out with the large rib overlapping the small.

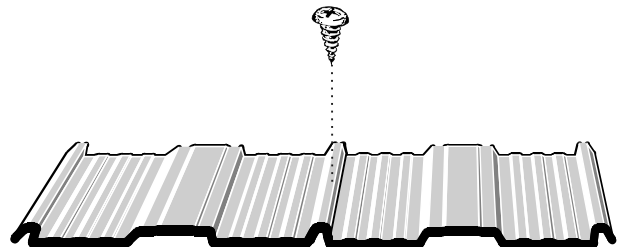

Screw the wall panels in the centre of the rib as shown.

2

Notched ends are orientated to the outer edges of the panel

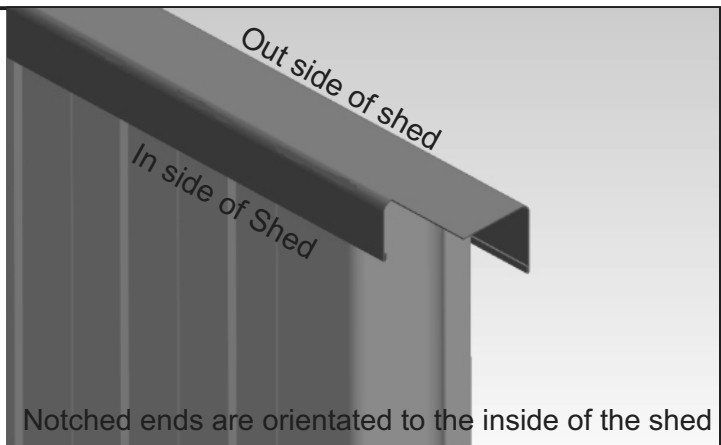
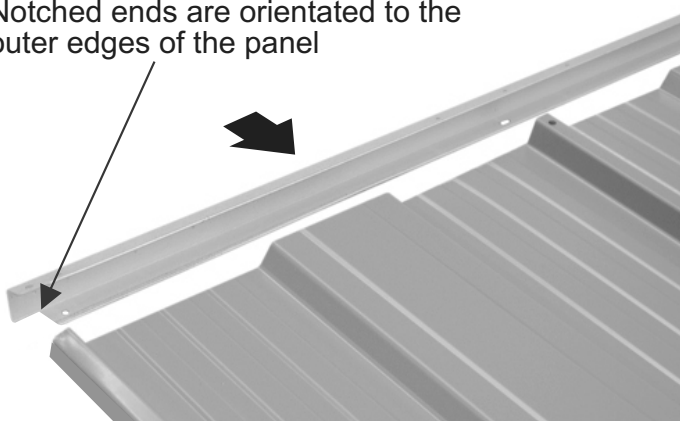

Notched ends are orientated to the inside of the shed

## REAR WALL - TOP & BOTTOM CHANNEL FIXING

1

Join M(1461) & M(1115)=2575  
 $2575-130=2445\text{mm}$

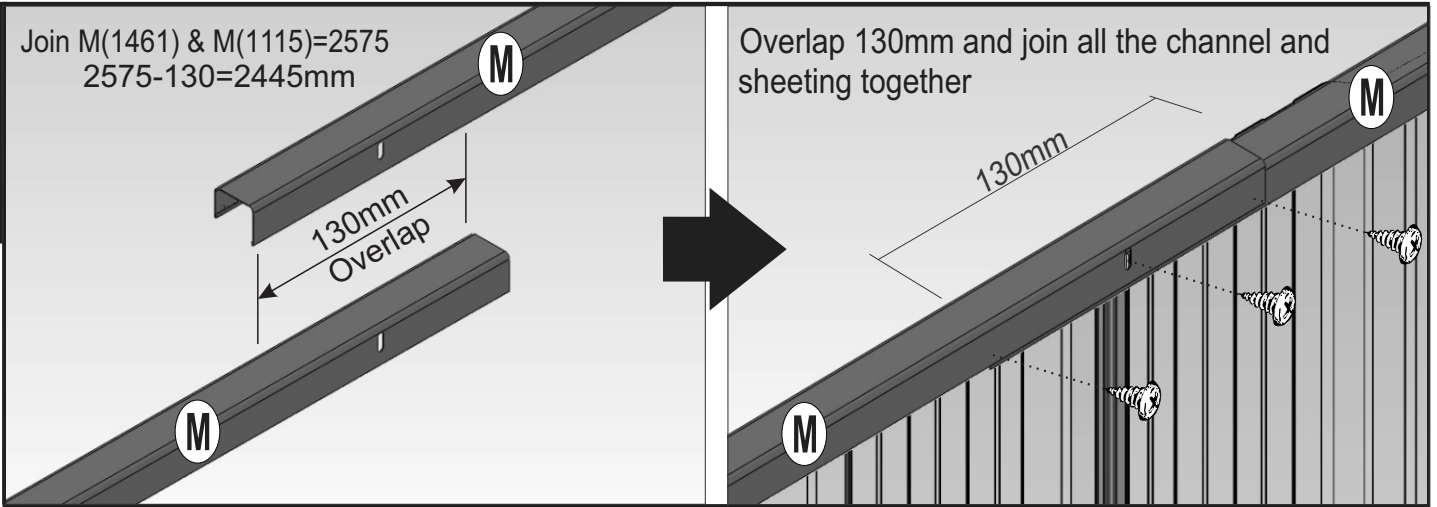

2

Join M (2445) & m (2099) => 4545mm  
 $4545-15=4530\text{mm}$

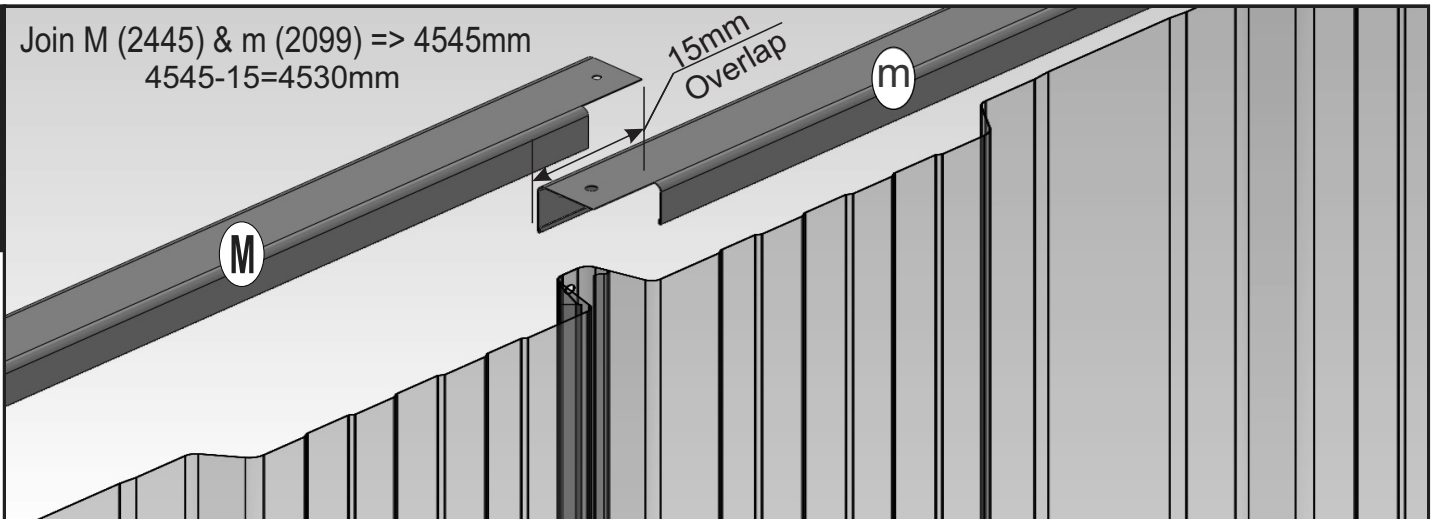

3

Overlap 15mm so that the holes align properly.  
Make sure to screw the channels through sheeting from the side.

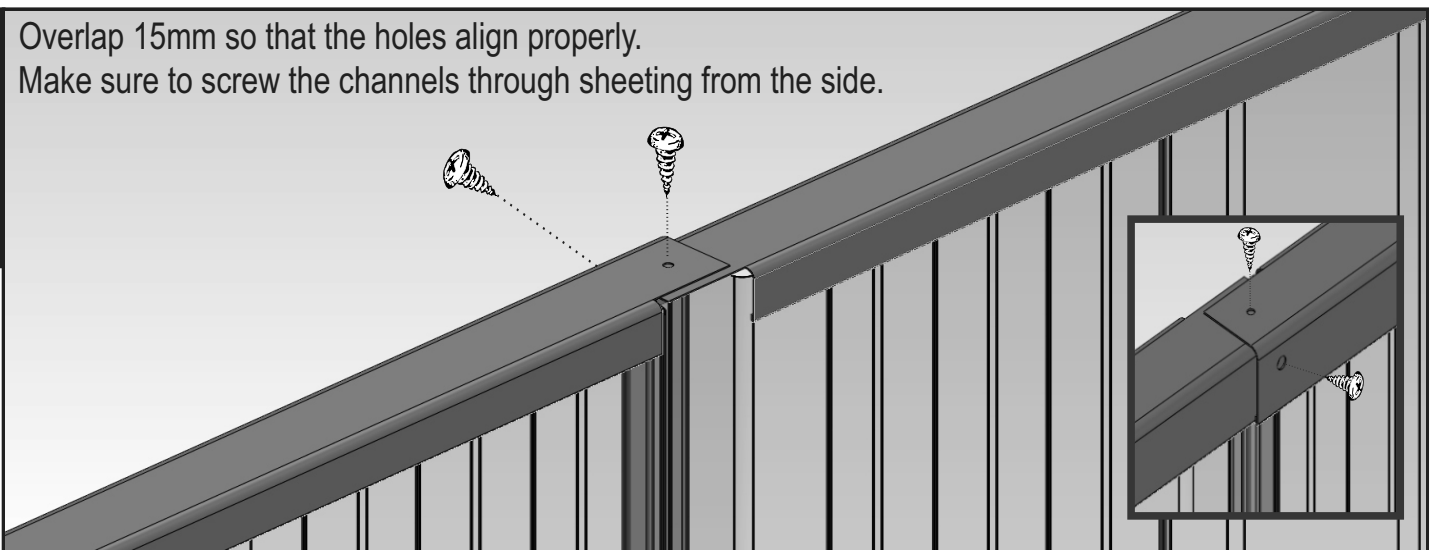

# FRONT WALL PANEL

Required to manipulate sheeting panel to align the channel holes

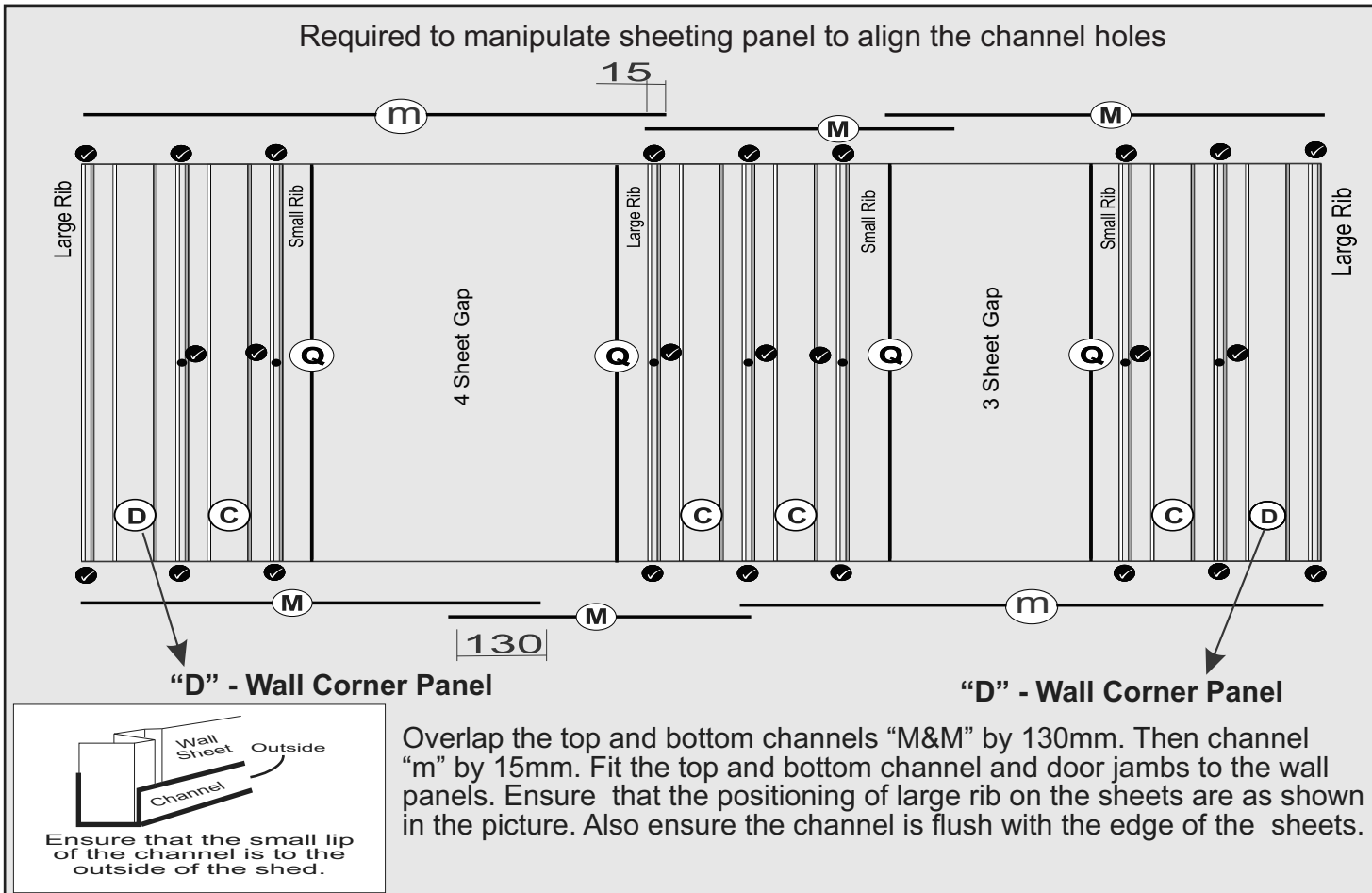

Overlap the top and bottom channels "M&M" by 130mm. Then channel "m" by 15mm. Fit the top and bottom channel and door jambs to the wall panels. Ensure that the positioning of large rib on the sheets are as shown in the picture. Also ensure the channel is flush with the edge of the sheets.

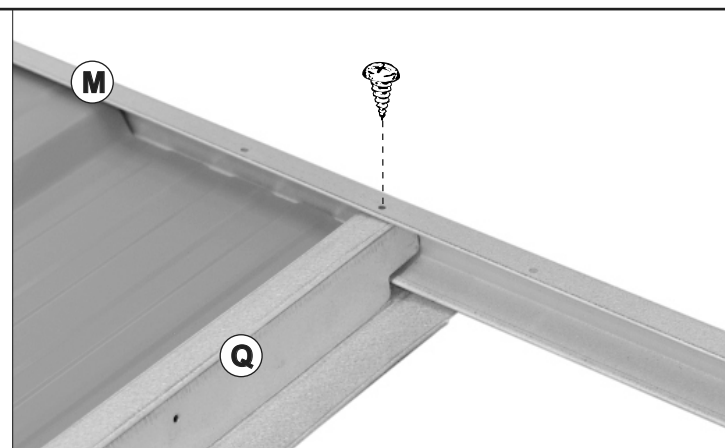
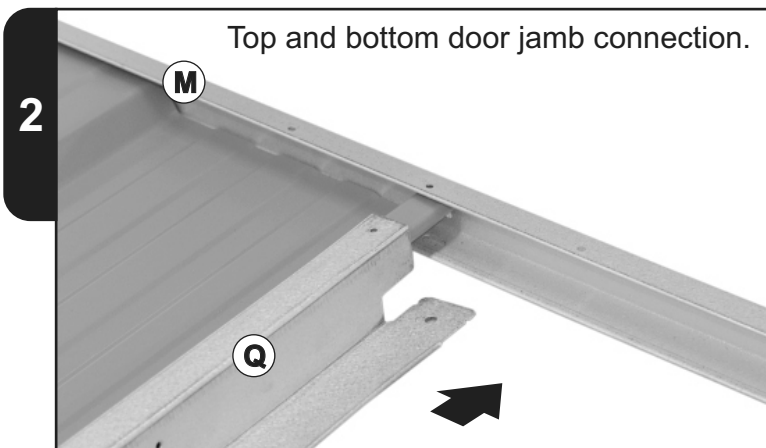
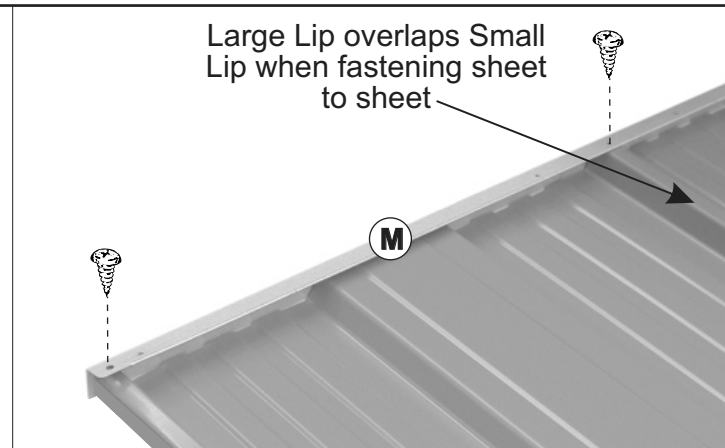
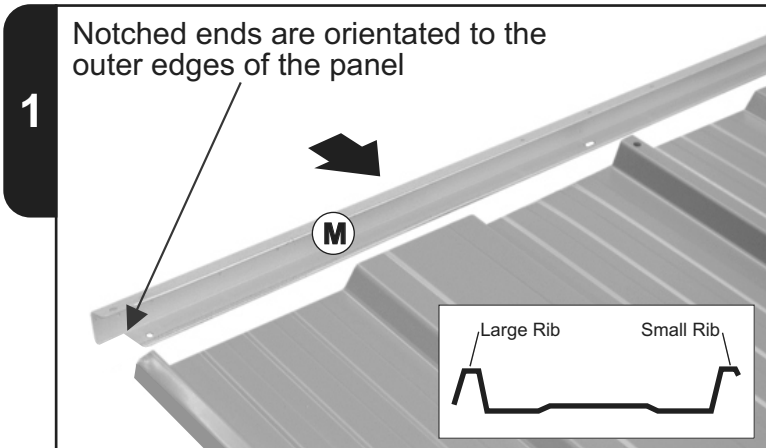

# FRONT WALL PANEL- 2x2 PANEL DOOR

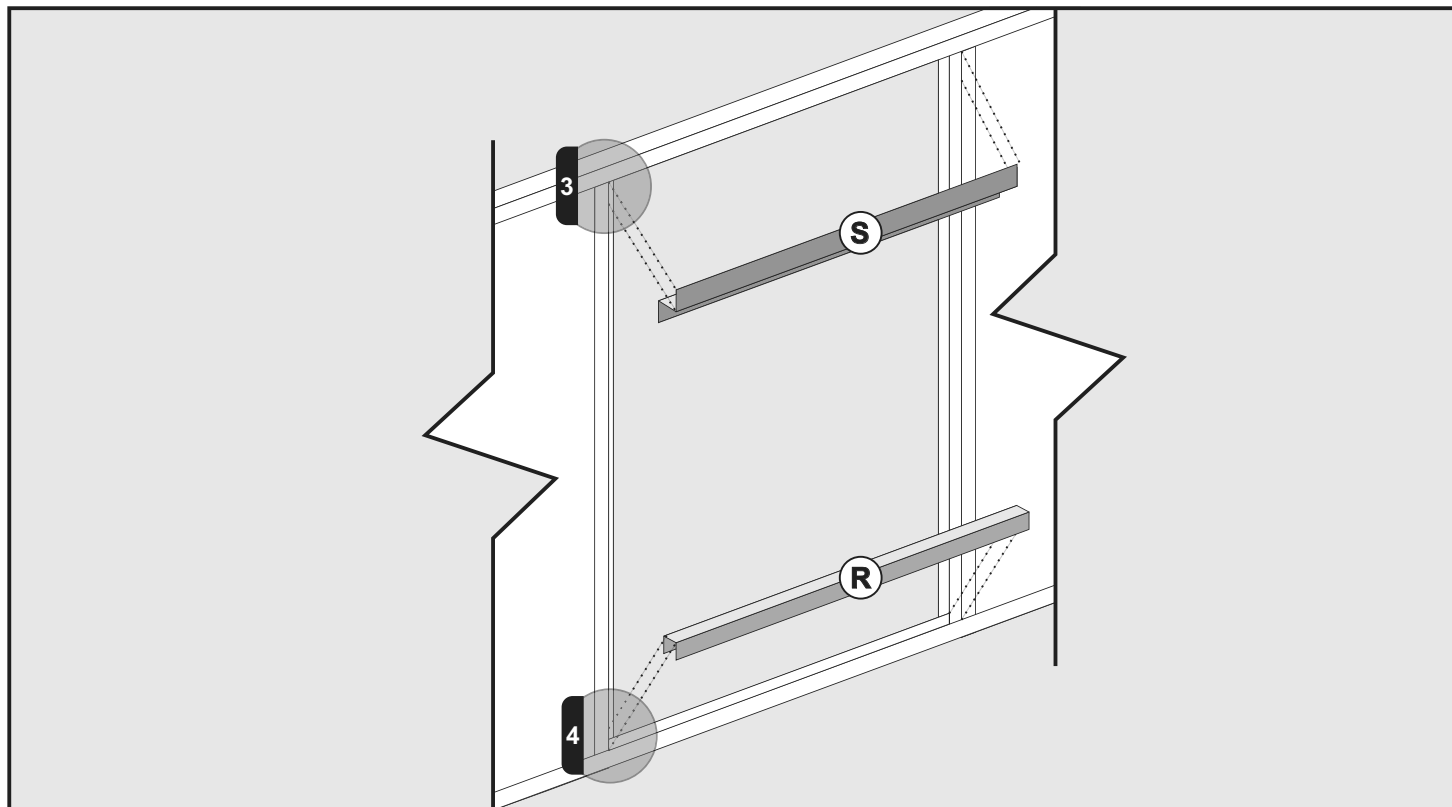

Fit the top door spacer and the bottom door spacer to the front wall panel as shown. Some pilot holes may need to be drilled with the included 2.5mm drill bit

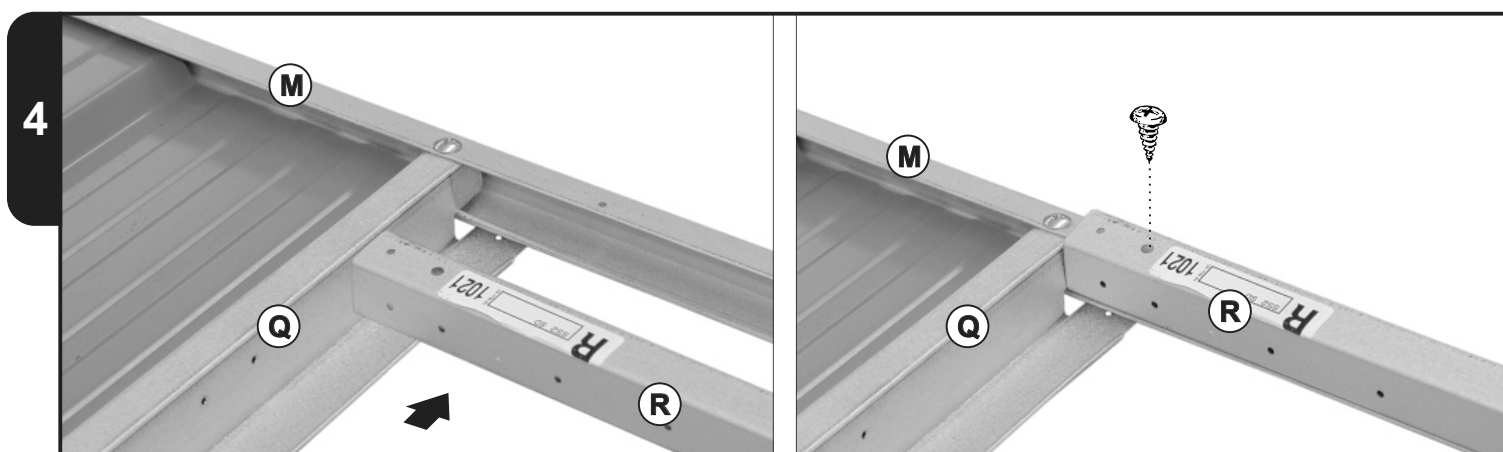
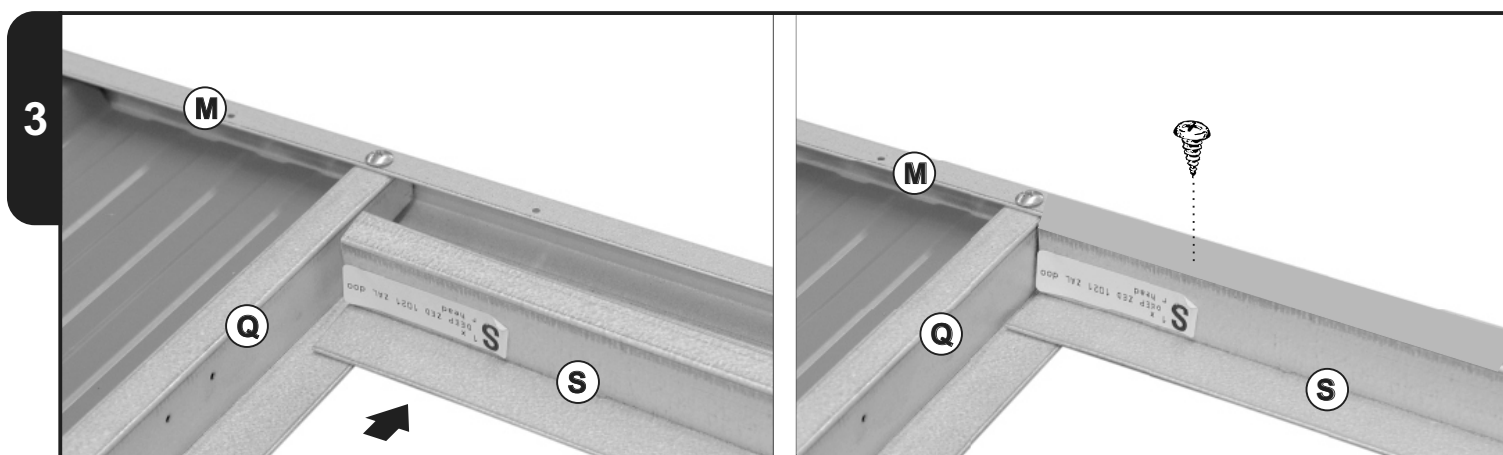

# FRONT WALL PANEL- 3 PANEL DOOR

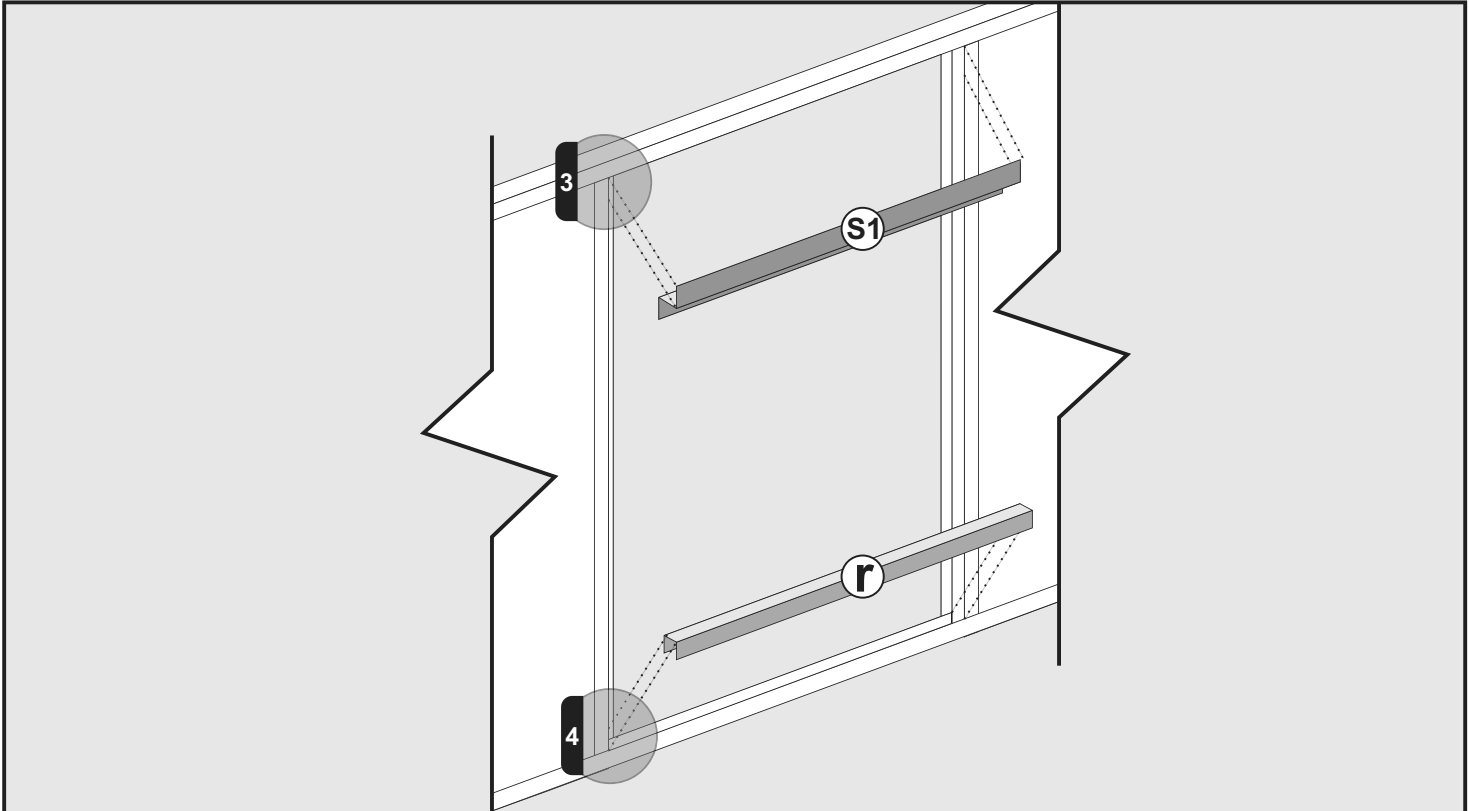

Fit the top door spacer and the bottom door spacer to the front wall panel as shown. Some pilot holes may need to be drilled with the included 2.5mm drill bit

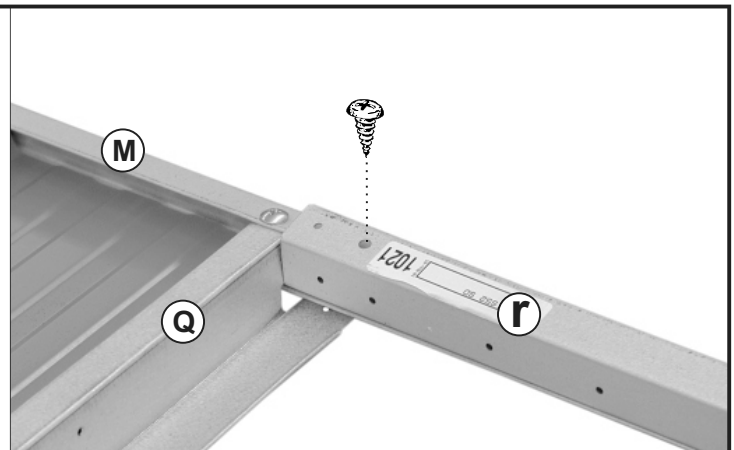
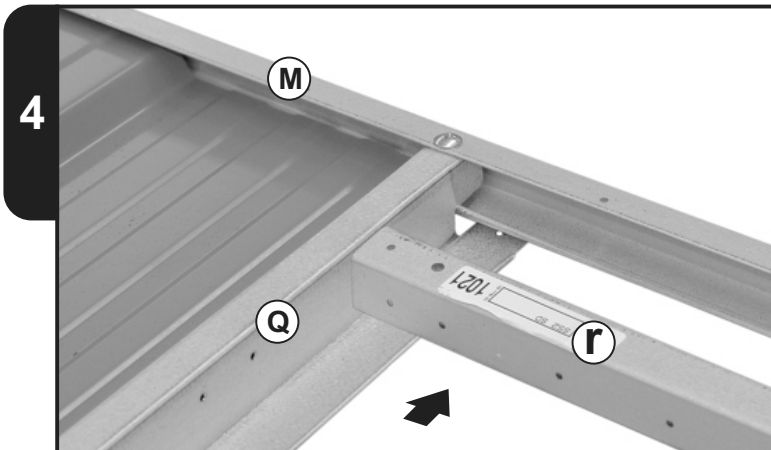
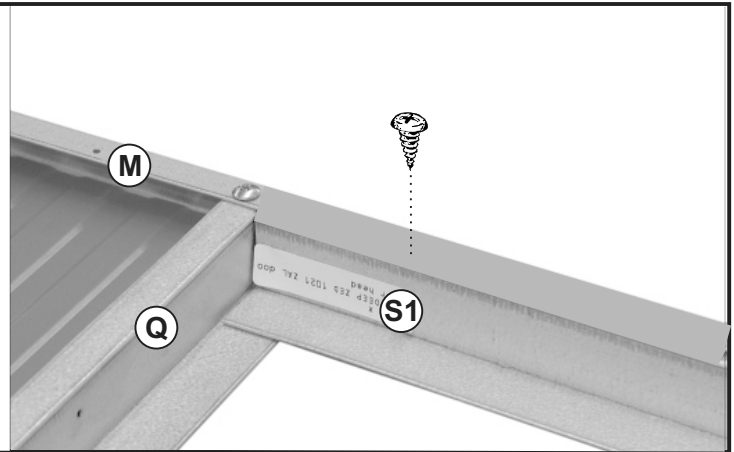
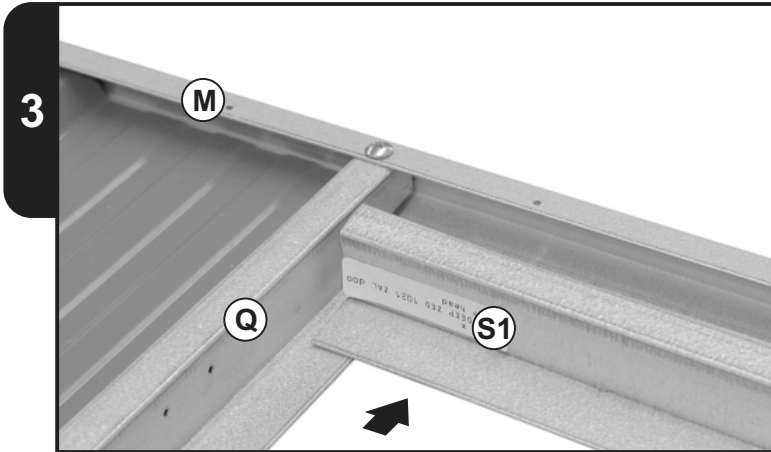

## DOOR CHANNEL FIXING

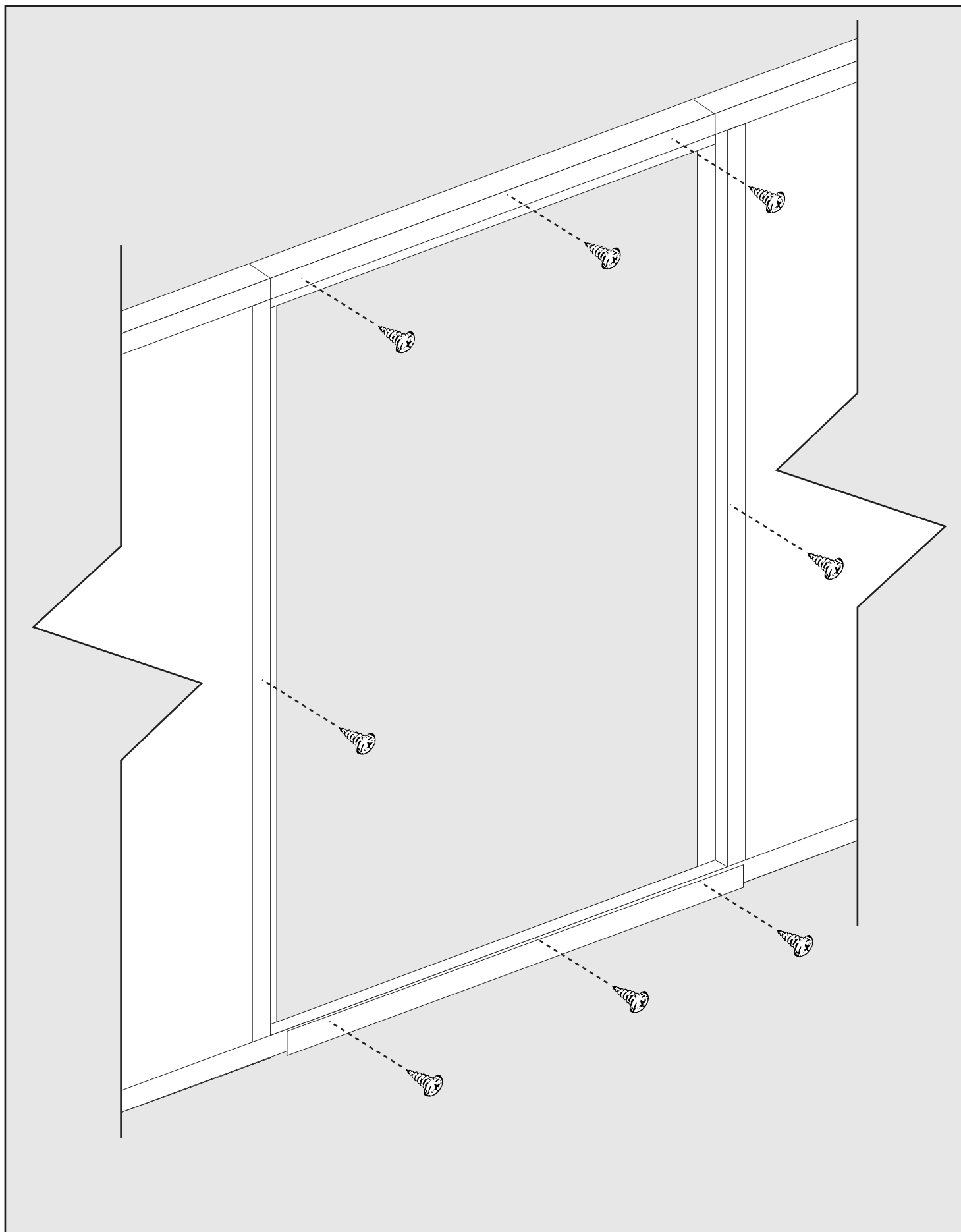

# GABLE WALL PANELS

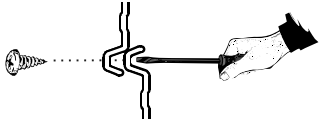

If you are having trouble screwing the channel to the sheets, chock behind the hole.

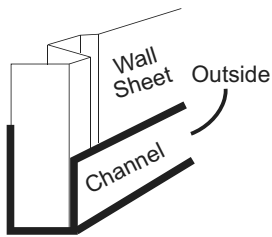

Ensure that the small lip of the channel is to the outside of the shed.

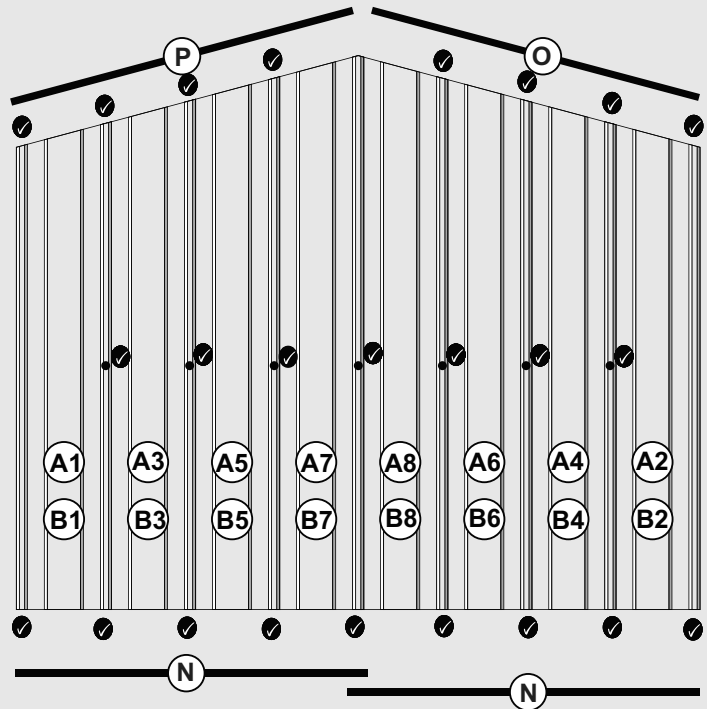
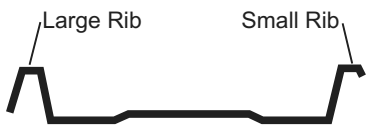

(A) Left Gable Panel Labels, (B) Right Gable Panel Labels

Make sure to assemble all panel "A" together for left wall and "B" for right. Overlap bottom channel by 130mm. Fit the top and bottom channel to the wall panels. Ensure the channel is flush with the edge of the sheets. Do not screw the ends of the channel to the sheets at this point.

1

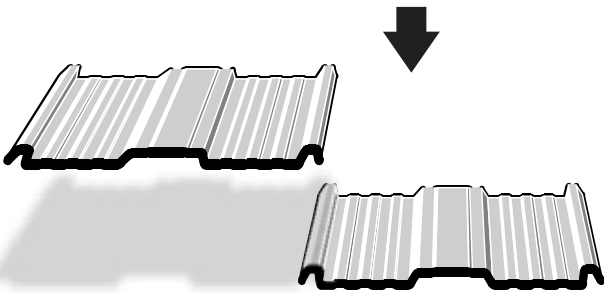

Lay the wall panels out with the large rib overlapping the small.

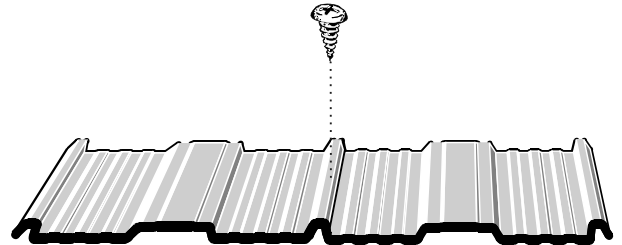

Screw the wall panels in the centre of the rib as shown.

2

Notched ends are orientated to the outer edges of the panel

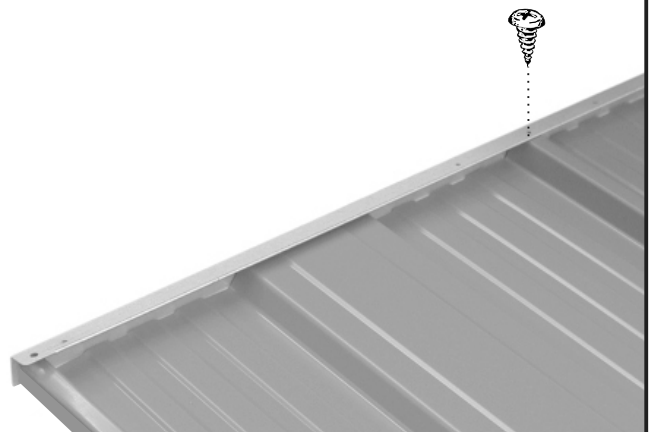
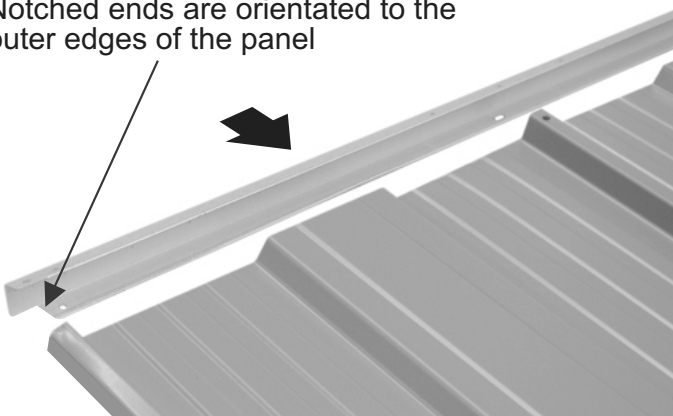

## FIT RIDGE BEAM BRACKETS

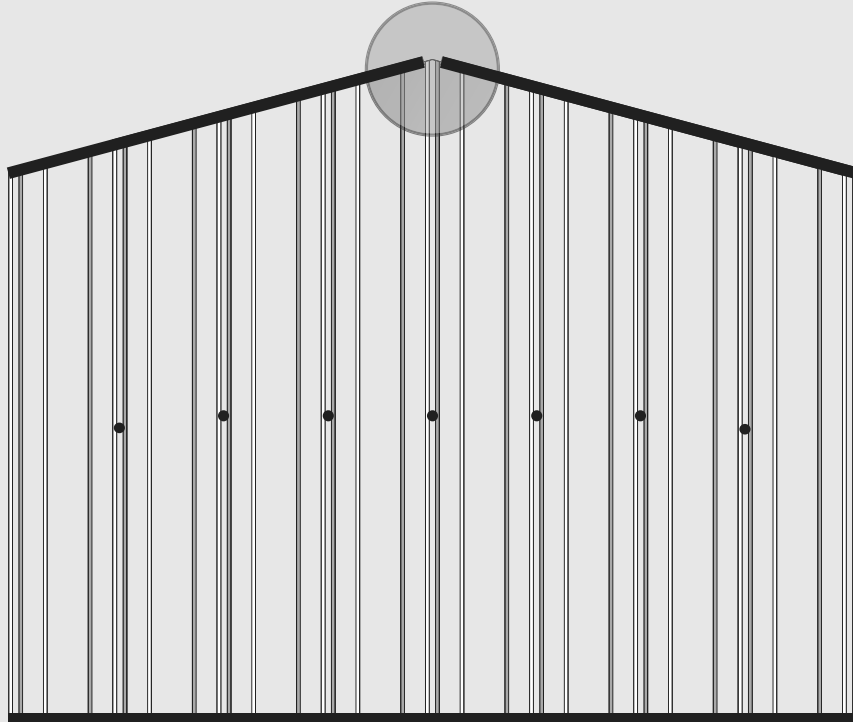

Fix the ridge beam brackets to the top of the gables using six (6) screws as shown below.

Pre Drill holes from inside the gable wall,  
Then fix from outside with 4 screws.

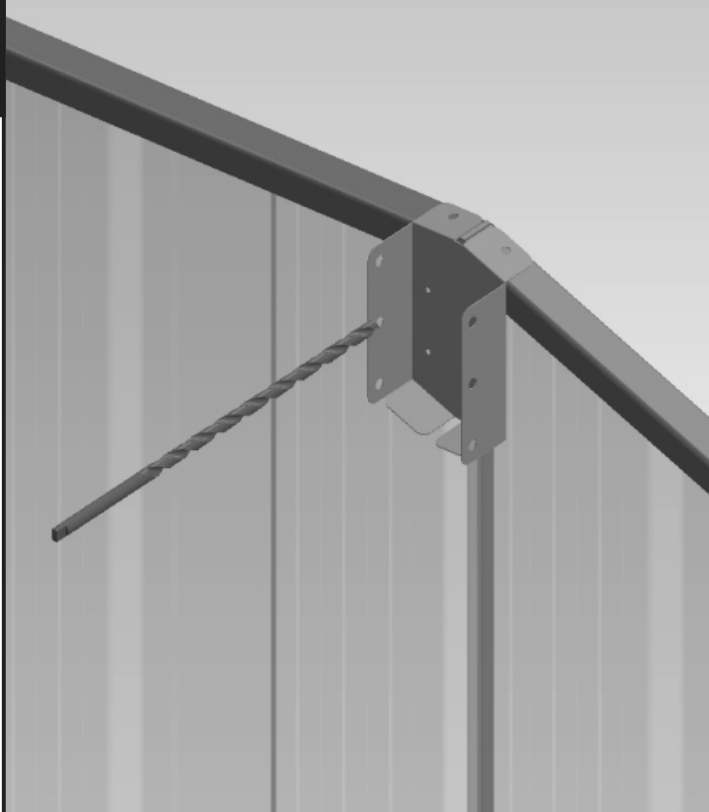

Secure brackets with six (6) screws as  
shown on both gable walls.

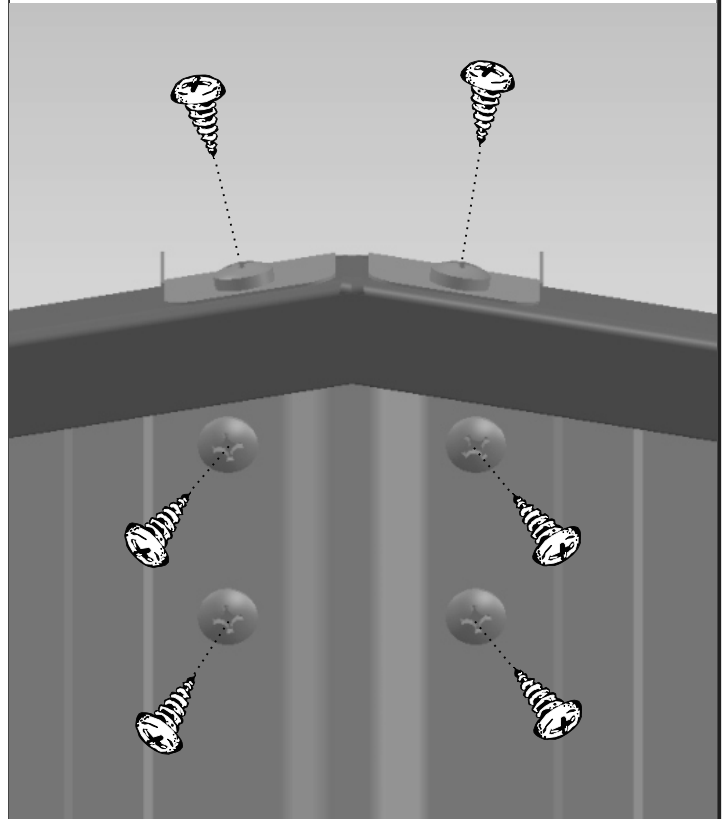

# ASSEMBLE AND FIT RIDGE BEAM

Over lap two ridge beam by 346mm so that pre drilled holes will align on the side face.

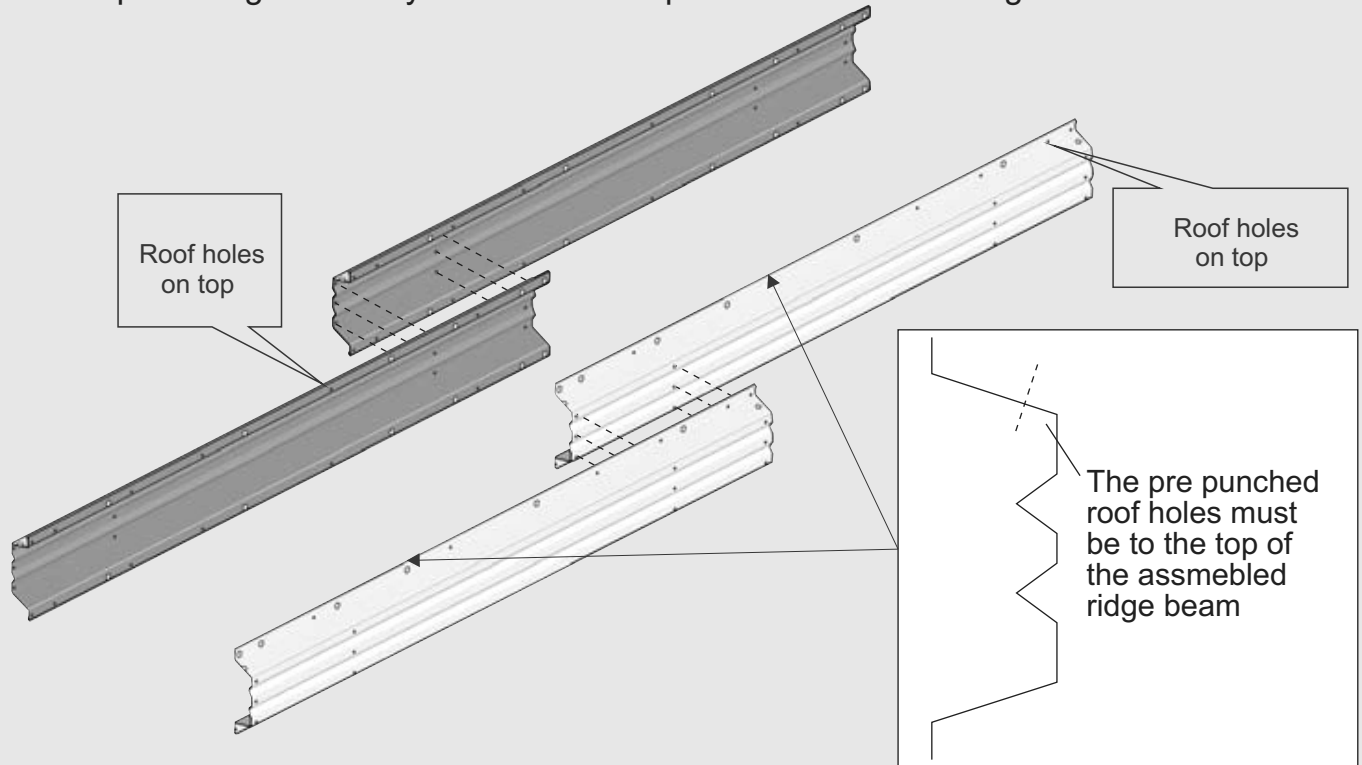

Assemble the ridge beam on the ground as shown below. Better to assemble one side in full length of 4478mm then do the other length, later box it together.

1

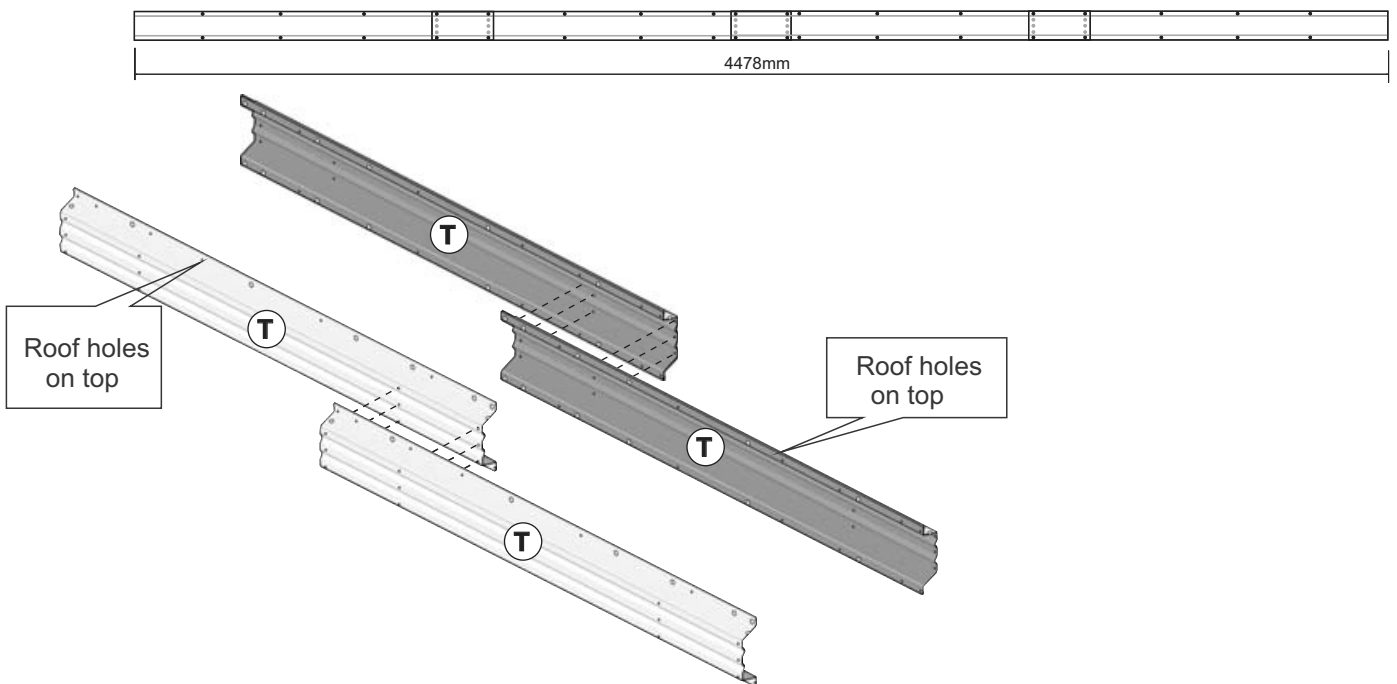

Overlap the two sides of the ridge beam securing them with six (6) screws per side. Ensure the pre-drilled roof panel holes are to the top. Screw the two sides together using the diagram top right as a guide. Join the whole 4 sets of ridge beam to get a total length of 4478mm.

## FIT RIDGE BEAM BRACKETS

This is a picture of workshop 2010, assembly procedure is same for workshop1510.

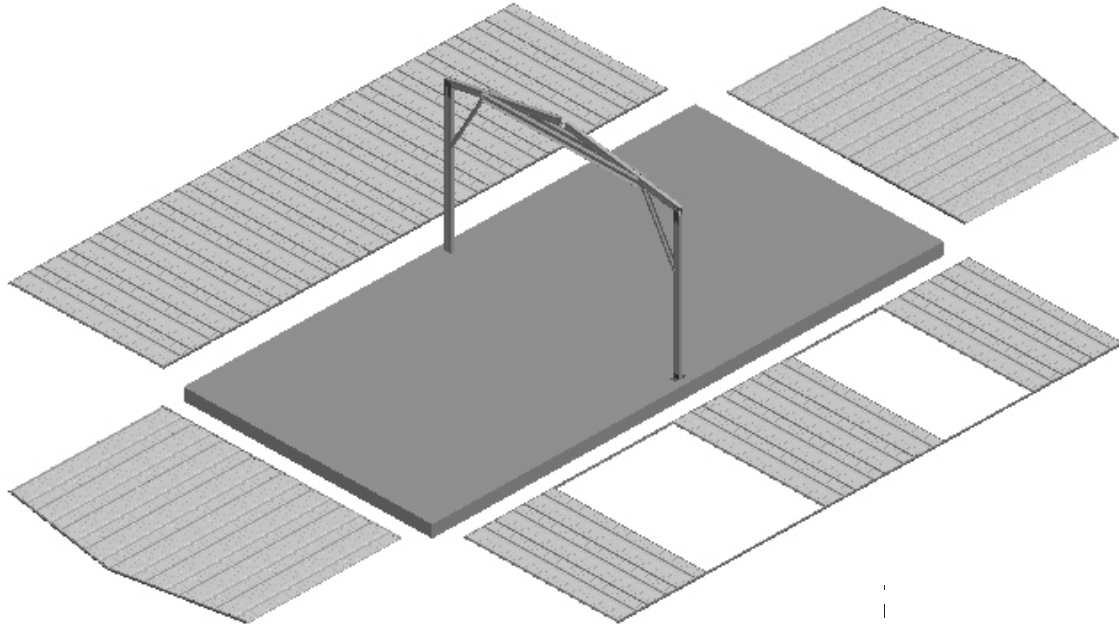

Once the four wall panels are assembled, they can now be placed as shown on the floor close to slab.

Use help of minimum of 3 person to lift and hold the panels. Take care not to assemble in windy condition.

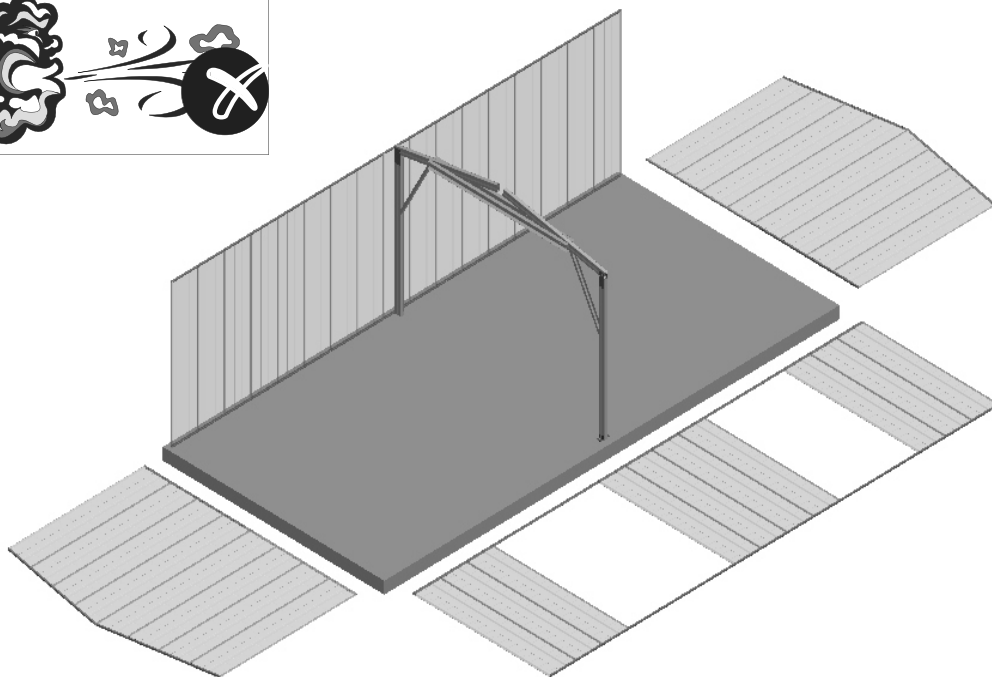
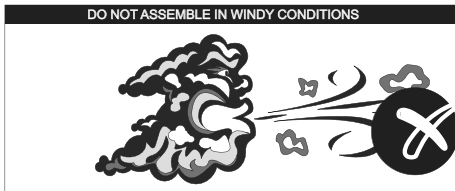

Lift the Rear wall Panel and place on the slab close to the portal leg. make sure to position the panel inside facing towards the portal frame, and center of the portal leg should be on the center of the rib where 7th panel (from 2x2 door) joint to 6th panel (from 3 panel door)

## FIT THE REAR WALL

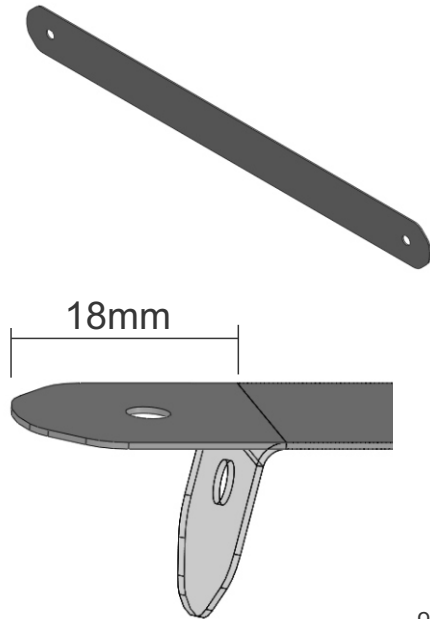

Bend one end of the strip by  $80^{\circ}$  as shown.

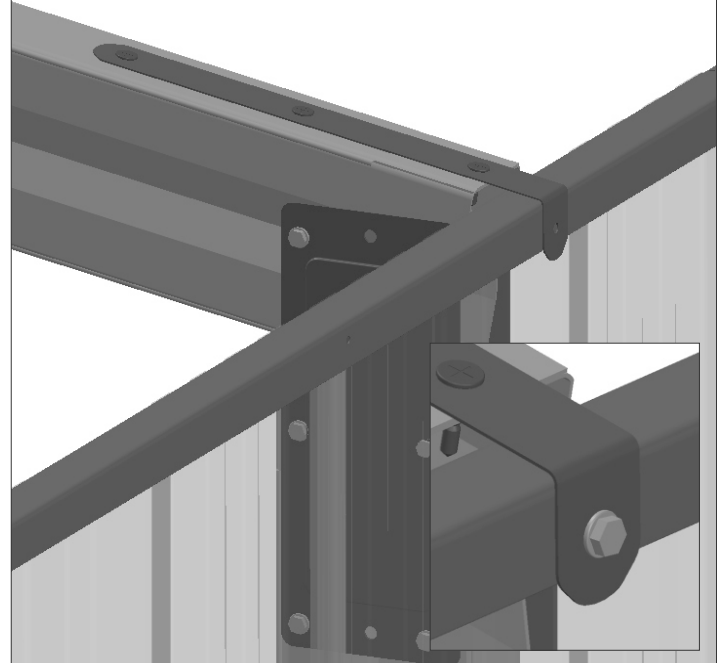

Now Screw the strip to the Rear wall channel as shown, then fix it to the portal. Make sure to fix the portal to the center of the rib where 7th (from 2x2 door side) and 8th. panel ribs join.

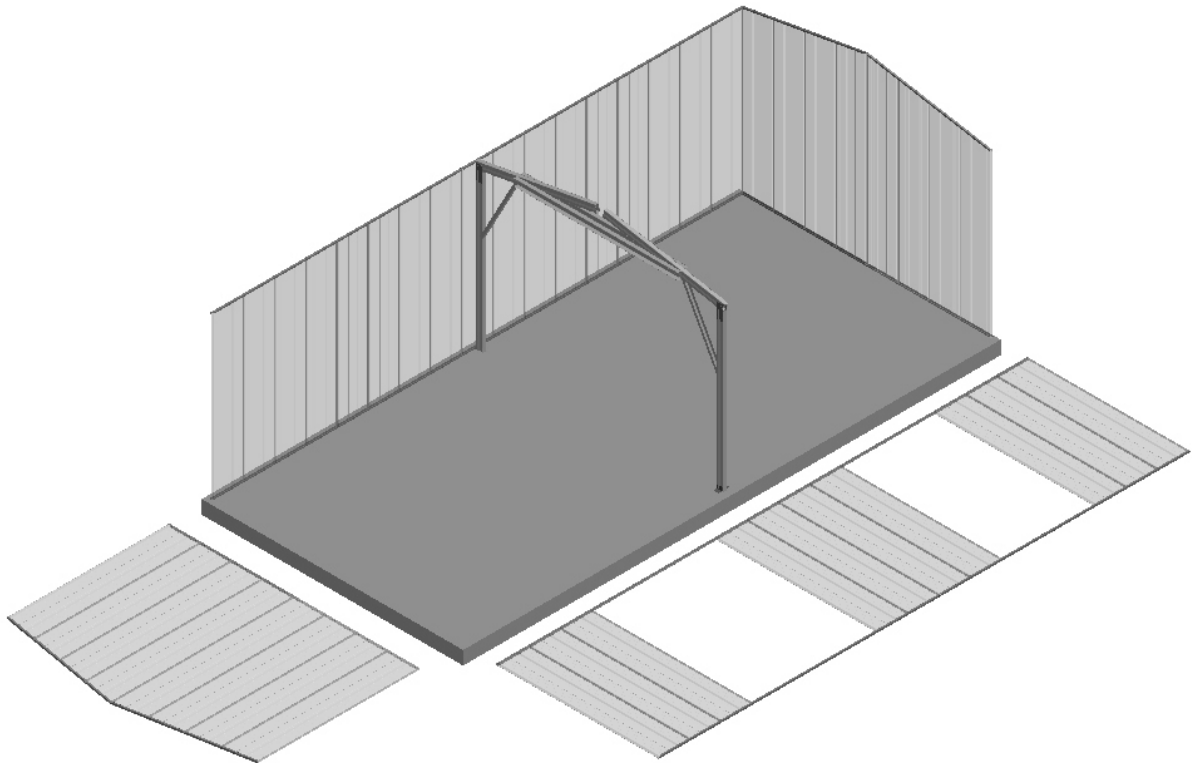

Now Lift the side wall panel and screw to the rear wall panel using bracket as shown over the page.

## FIT THE REAR & SIDE WALL

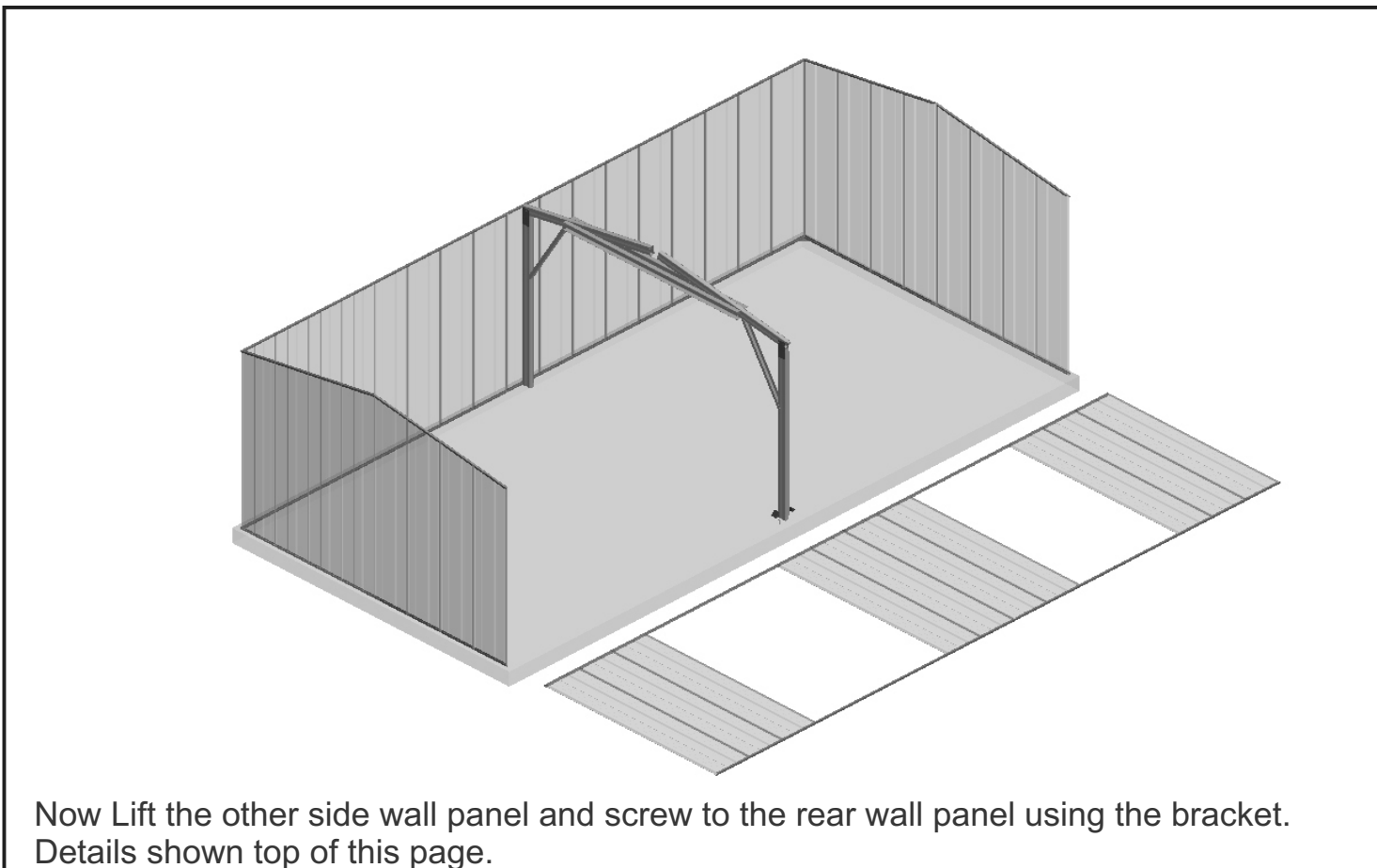
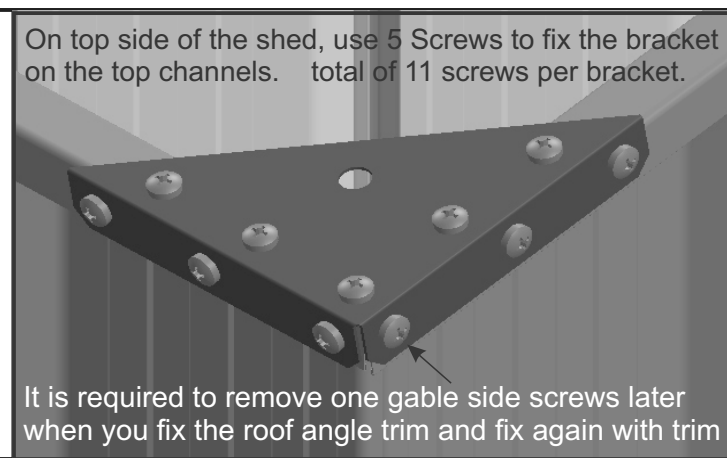
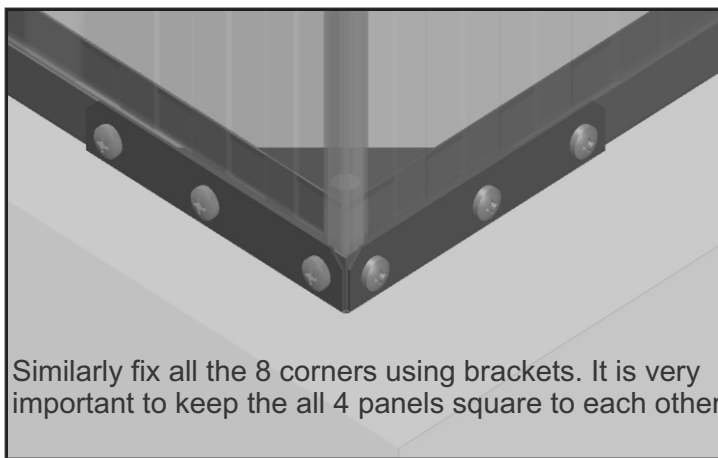
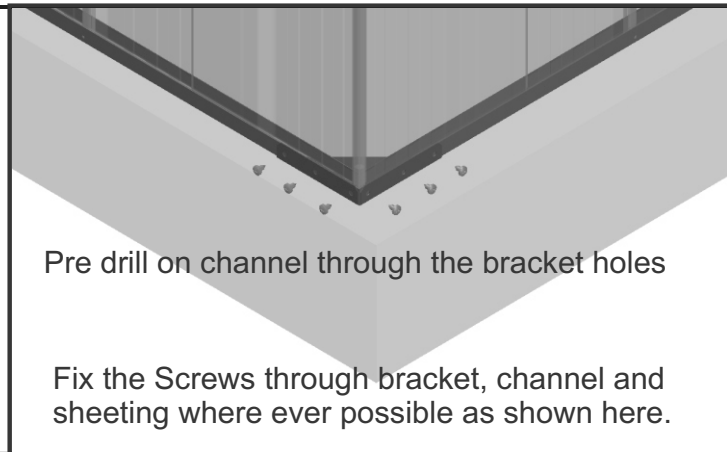
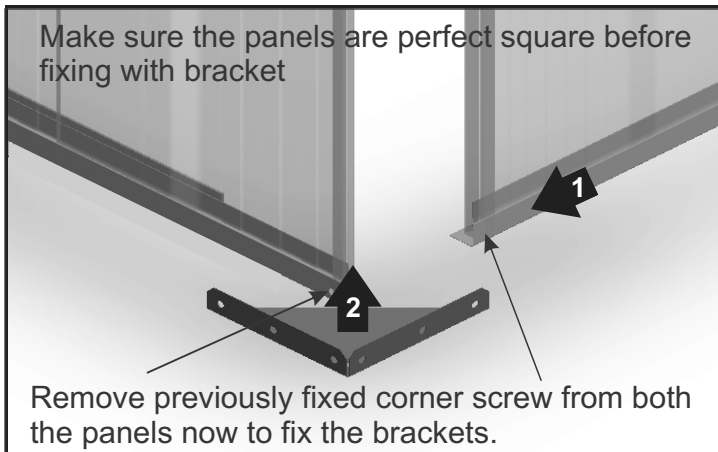

## FIT THE FRONT WALL

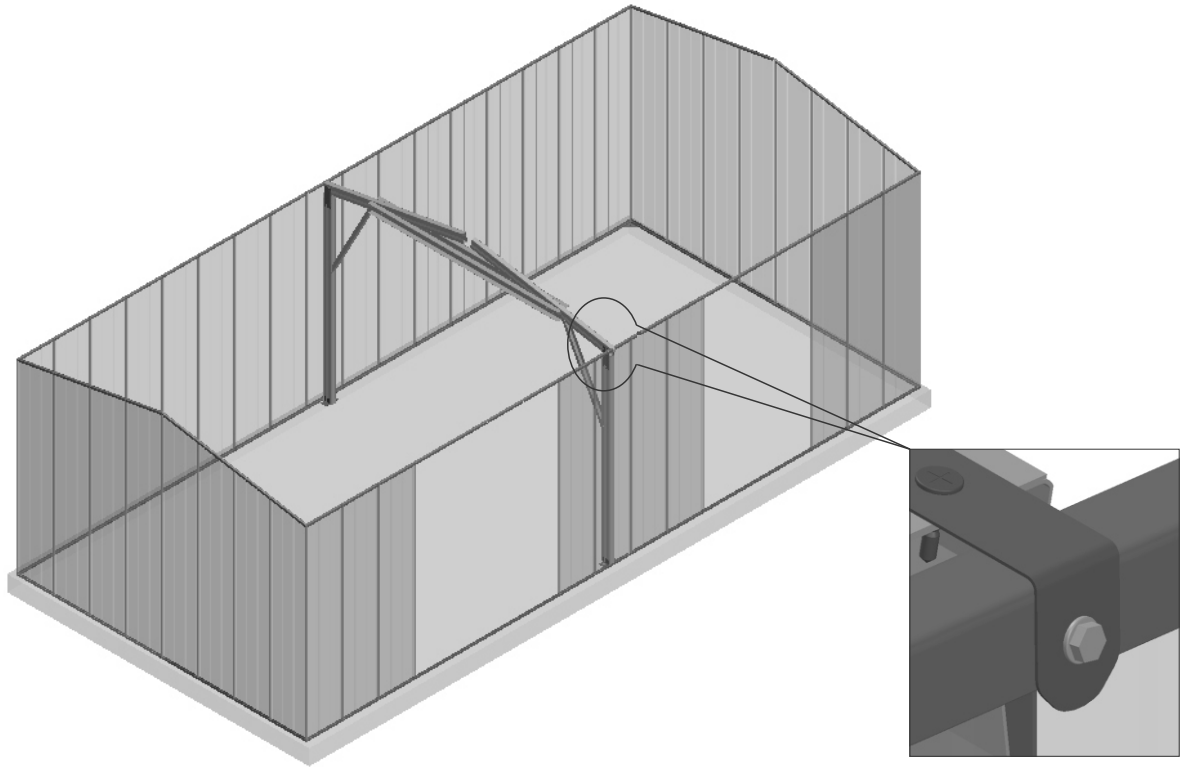

Lift the Front Wall panel to position and join it using the corner brackets as shown previously. Also make sure to fix wall panel with portal using the bend Gusset strip as shown on rear wall fixing.

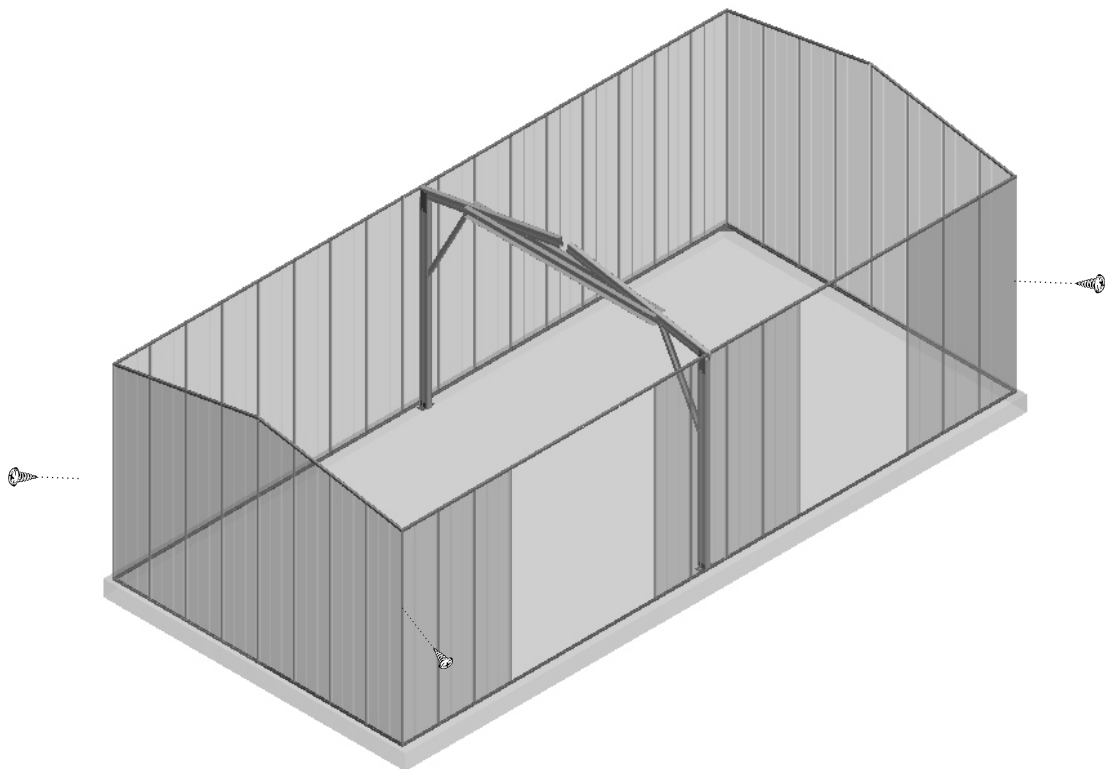

Screw 4 corners at the mid pint of the shed using the pre drilled holes.

## ASSEMBLE AND FIT RIDGE BEAM

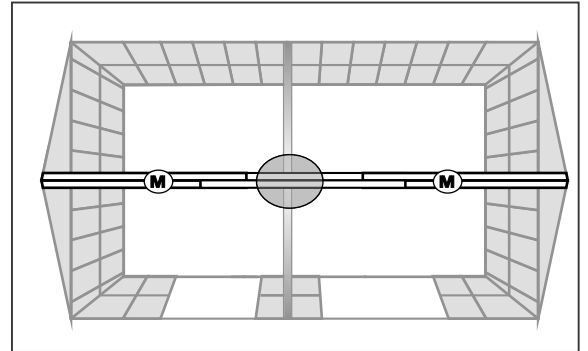
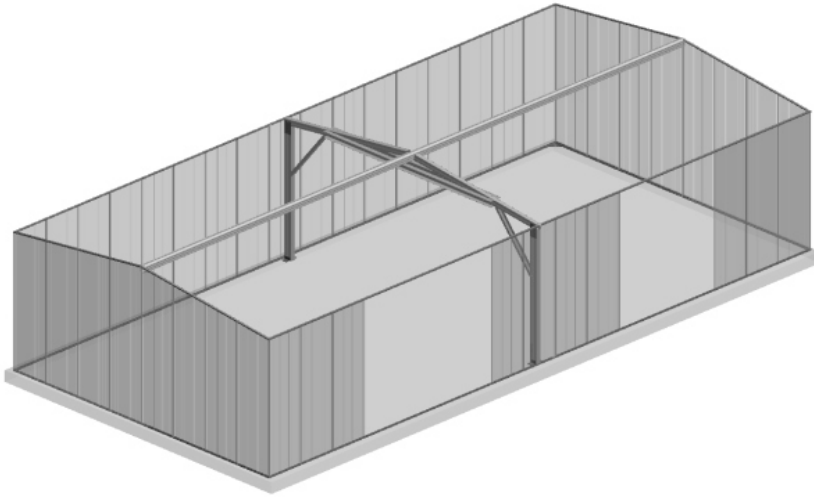

Fix ridge beam to the portal as shown. Make sure the pre drilled holes for the roof panel are on top.

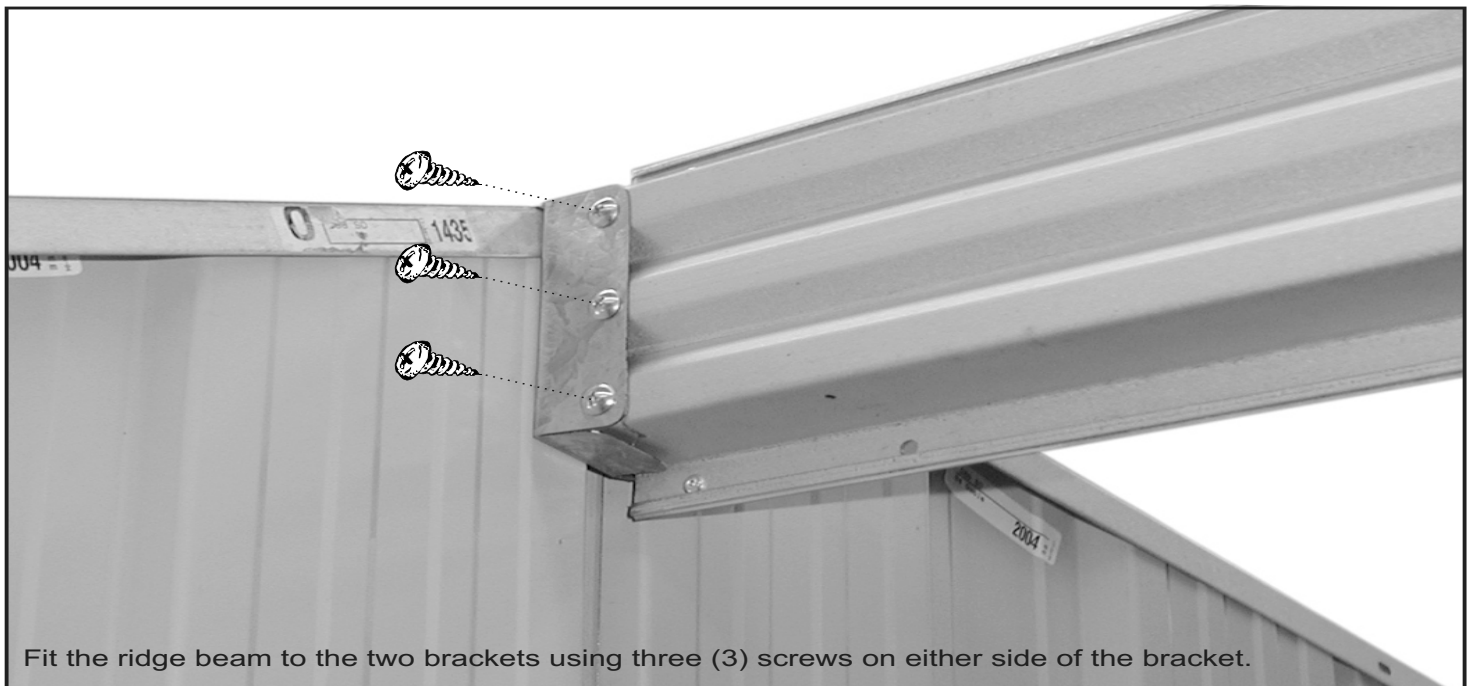
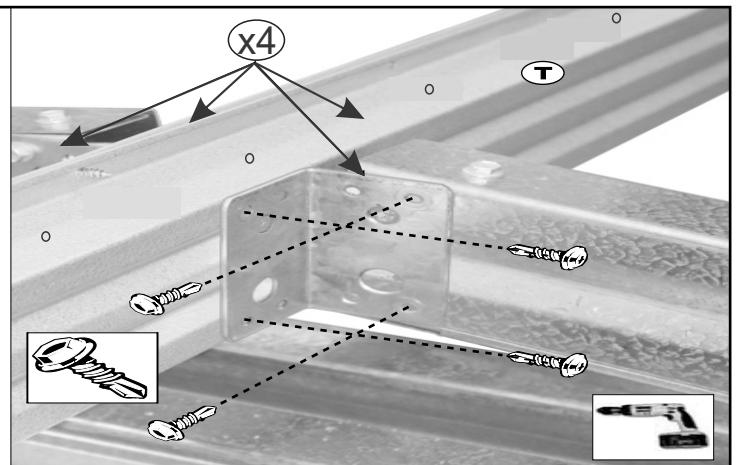
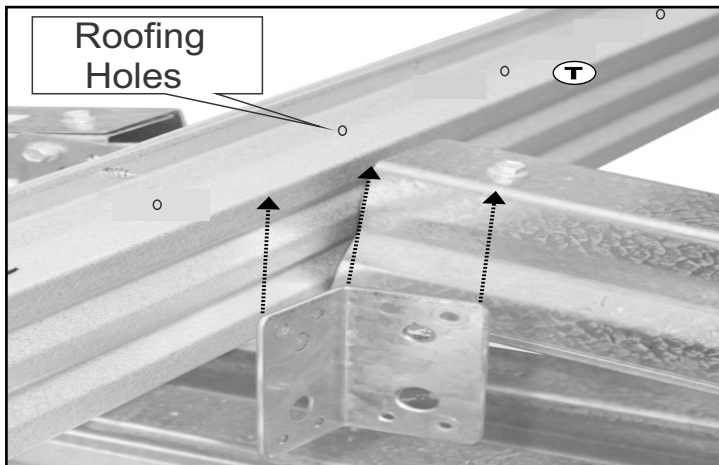

Fit the ridge beam to the two brackets using three (3) screws on either side of the bracket.

# FIT ROOF AND TRIMS

1

Screw the door side of the roof on first (do not start the rear side yet). Work from right to left ensuring the large rib is over the small rib. (If you are installing a skylight, please refer to the instructions at the end of this booklet)

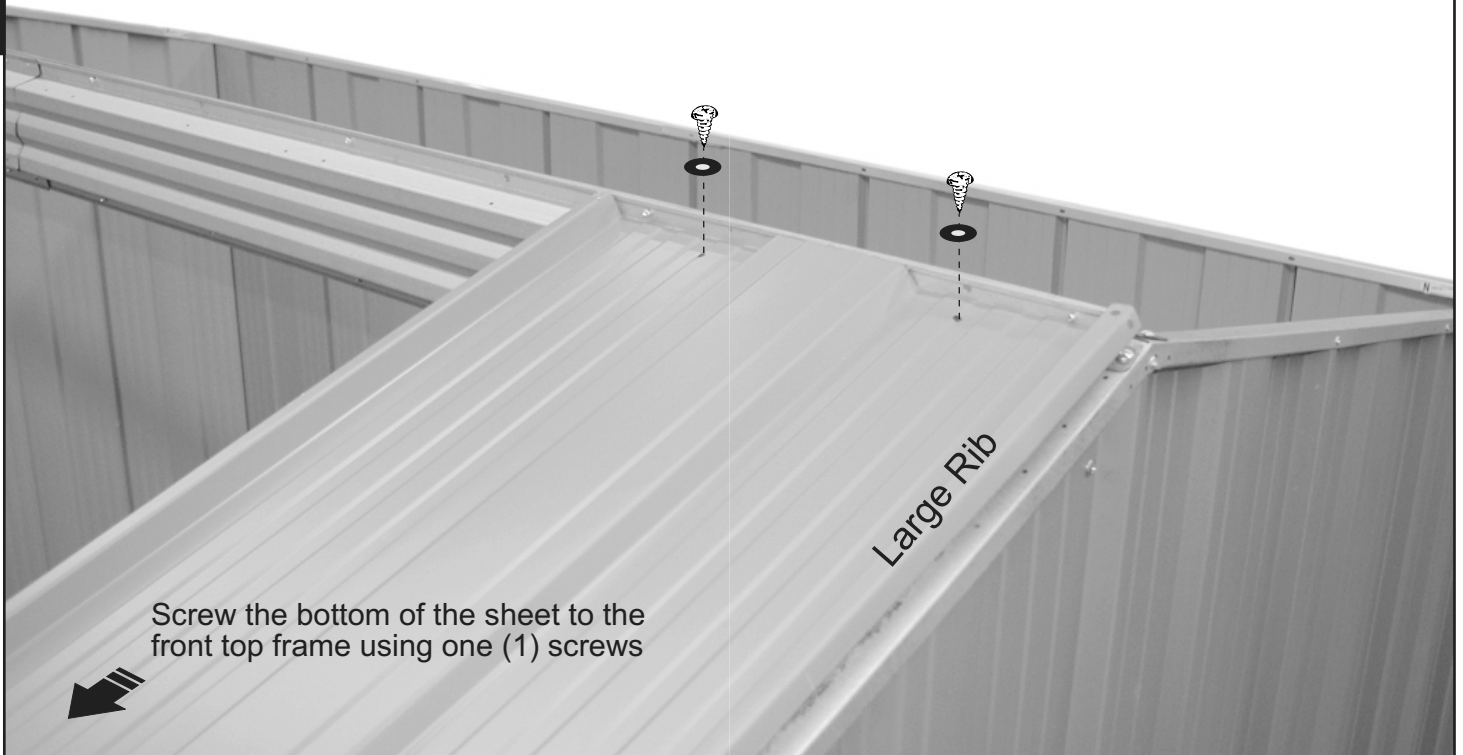

2

Fix the first two (2) sheets of the rear side then place the first ridge cap (do not screw at this stage).

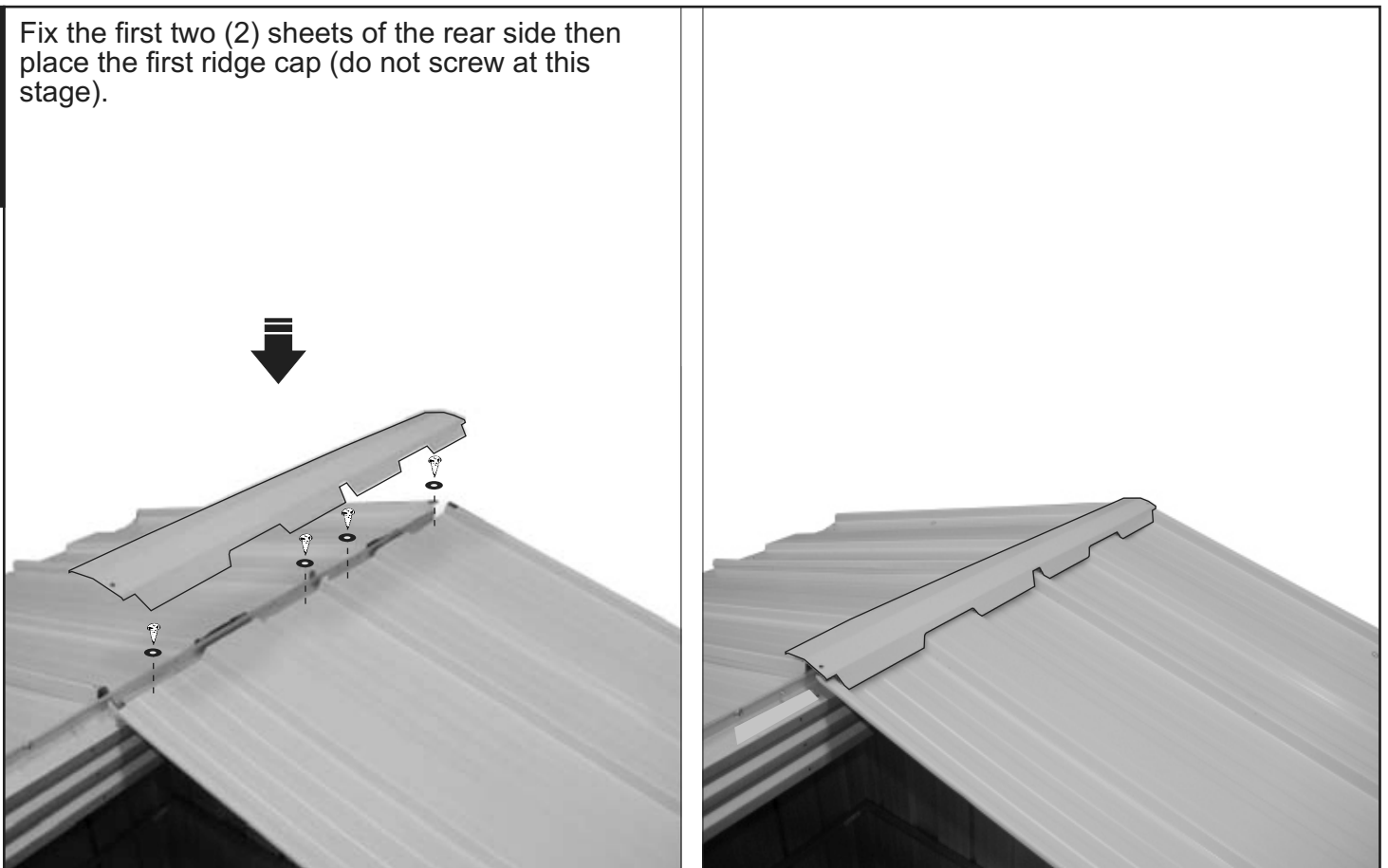

## FIT ROOF AND TRIMS

3

Fix the next two (2) sheets then fit the second ridge cap. Fix this as shown to the right.

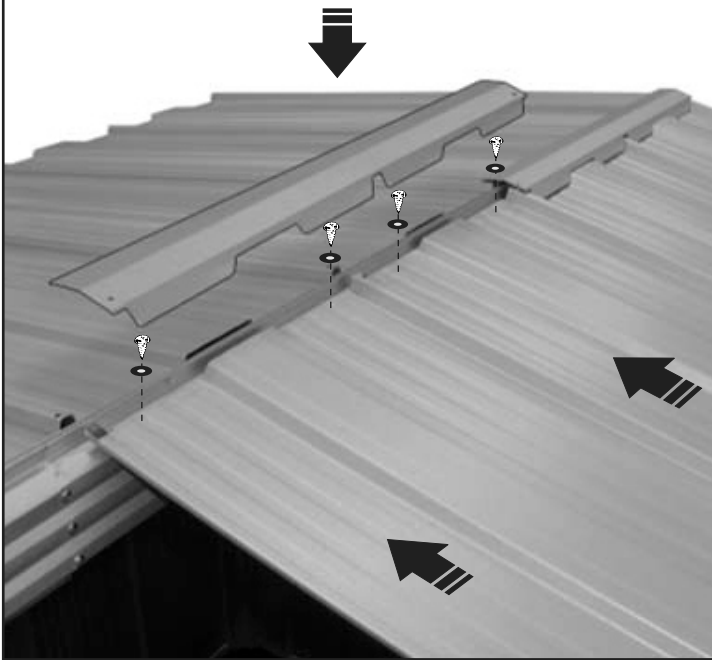

Finish the roof in the same manner.

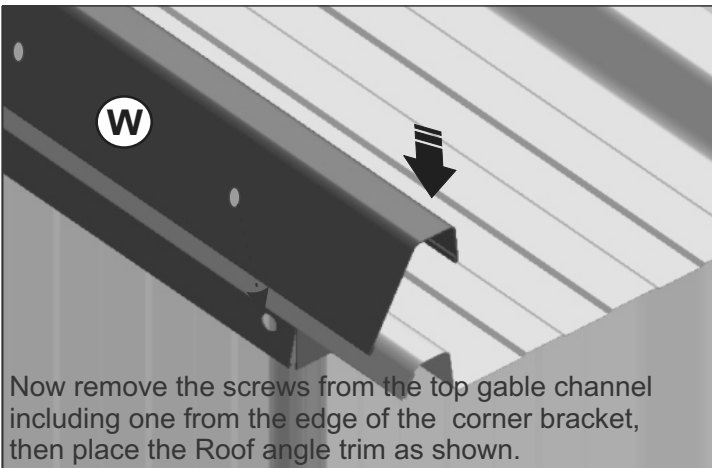
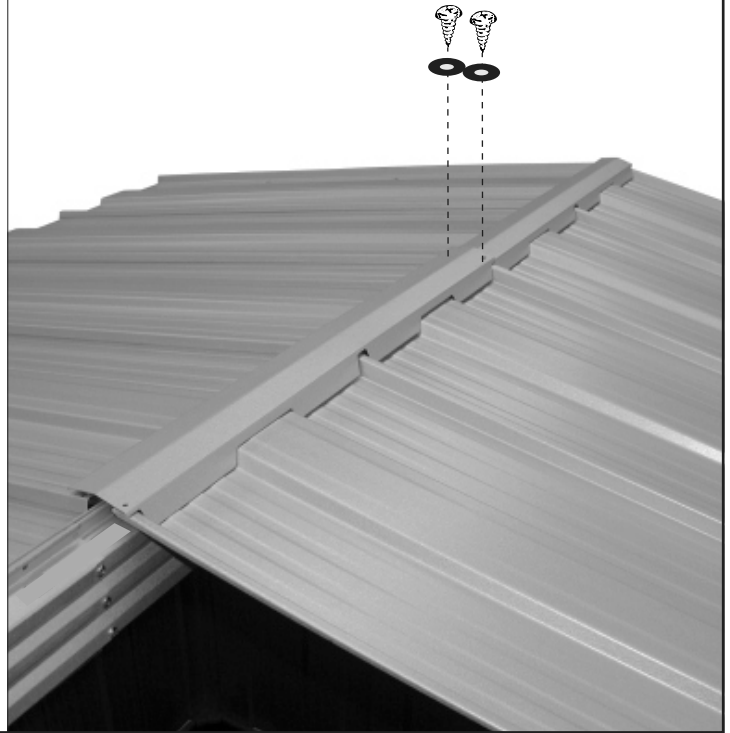

Now remove the screws from the top gable channel including one from the edge of the corner bracket, then place the Roof angle trim as shown.

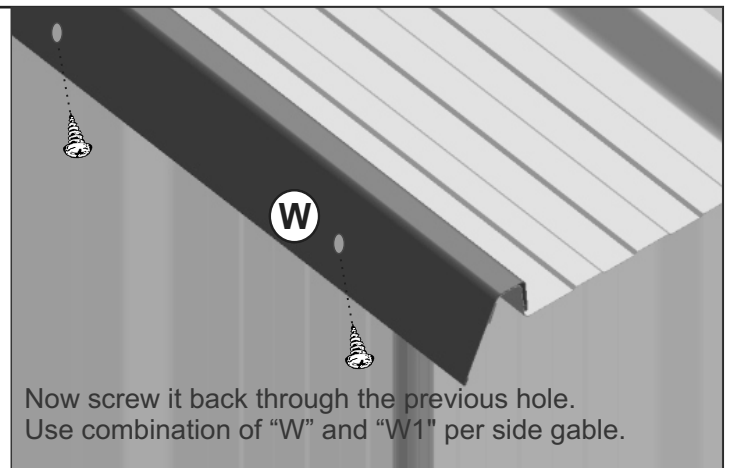

Now screw it back through the previous hole. Use combination of "W" and "W1" per side gable.

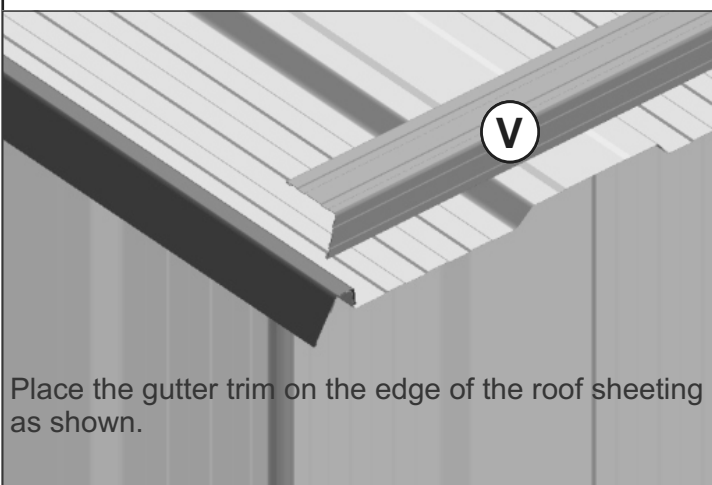

Place the gutter trim on the edge of the roof sheeting as shown.

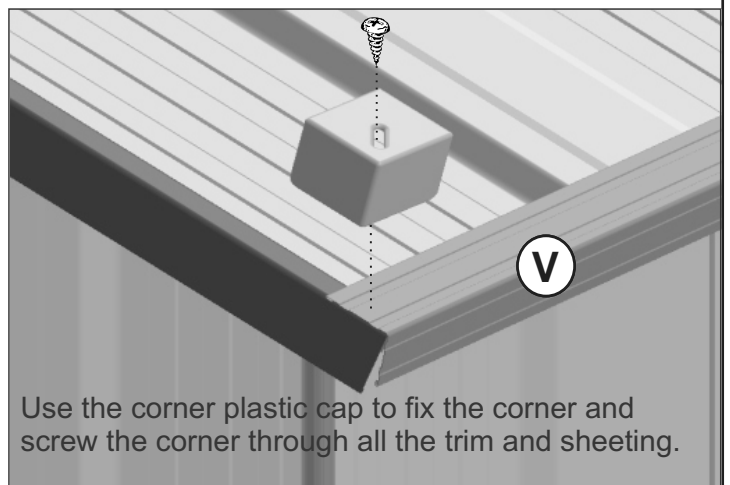

Use the corner plastic cap to fix the corner and screw the corner through all the trim and sheeting.

## FIT ROOF AND TRIMS

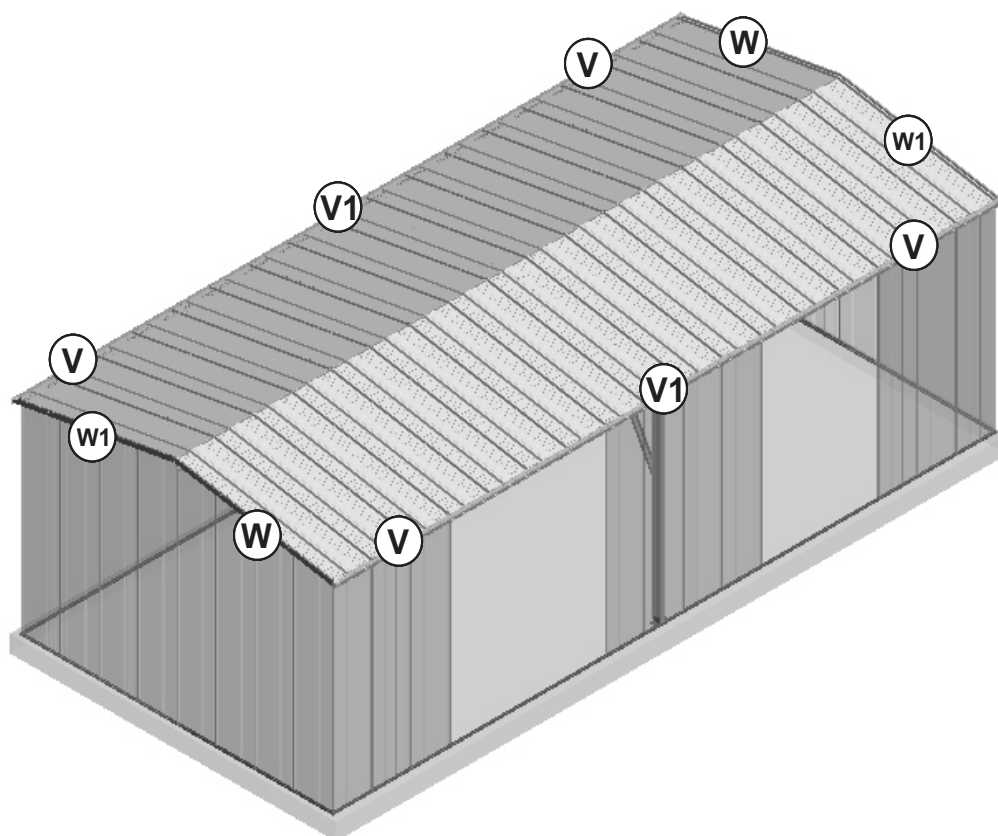

Position the channel as shown in here and fix it with the sheeting. use pre drilled holes to screw through.

# ASSEMBLE DOOR

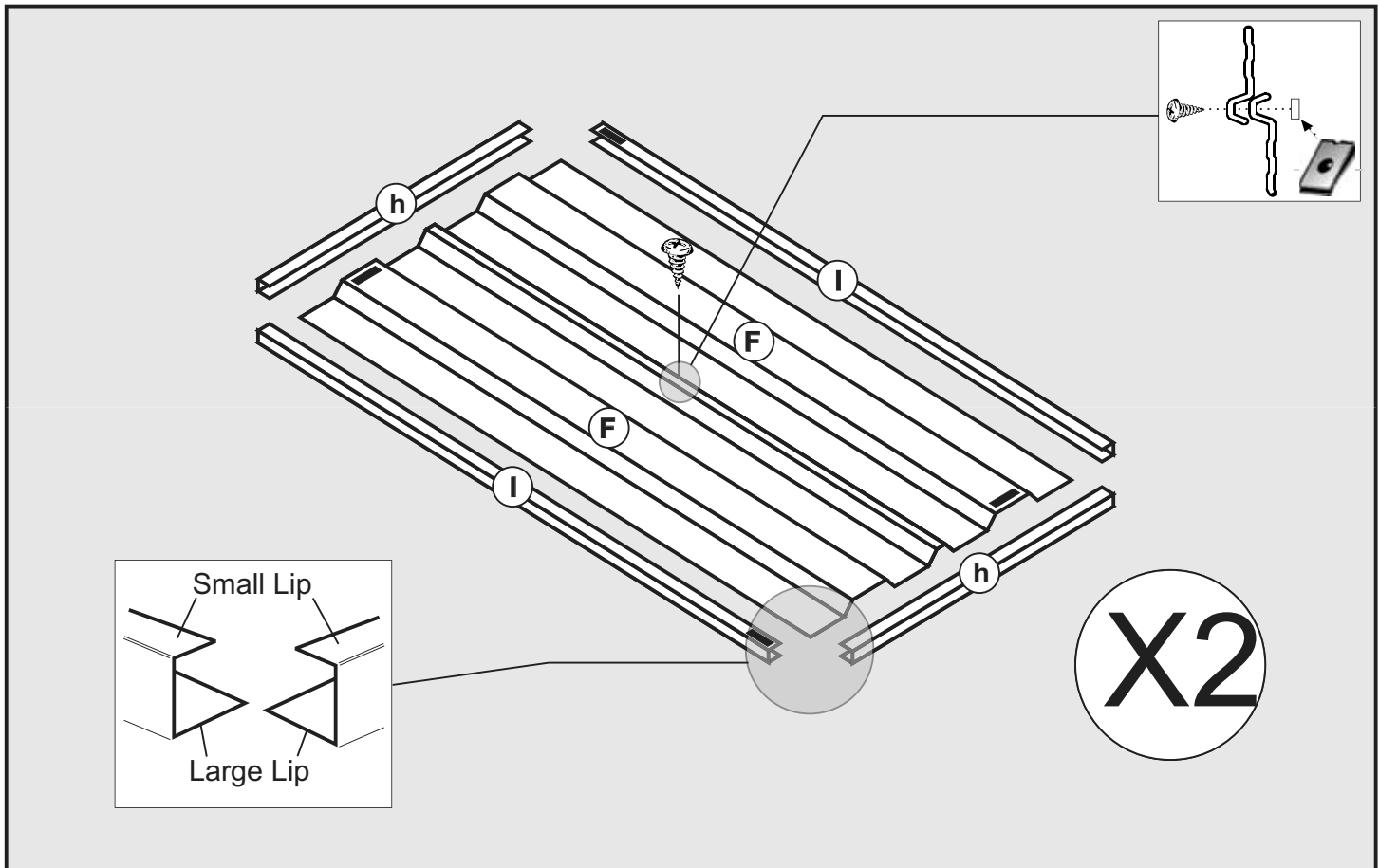

1

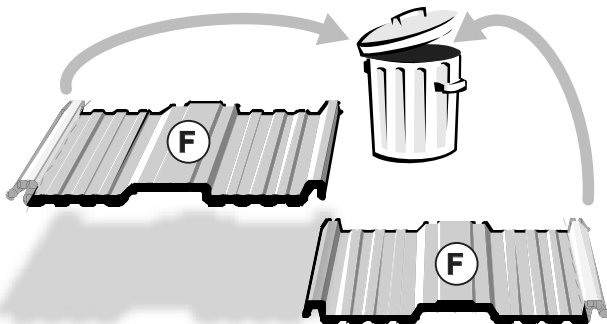

Both of the door sheets come with one rib partially slit. Break them off and discard them.

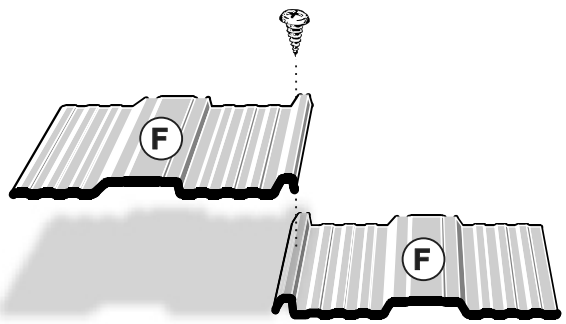

Screw the sheets in the centre.

2

Frames slide under the sheet as shown. Ensure the small lip of the frame is to the top.

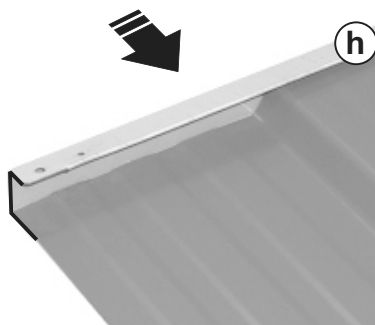

Fix door frames with a screw in each corner. Ensure that the big hole sits over the small.

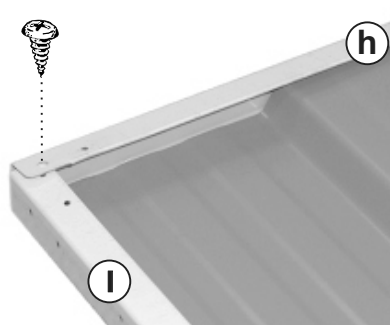

# ASSEMBLE DOOR

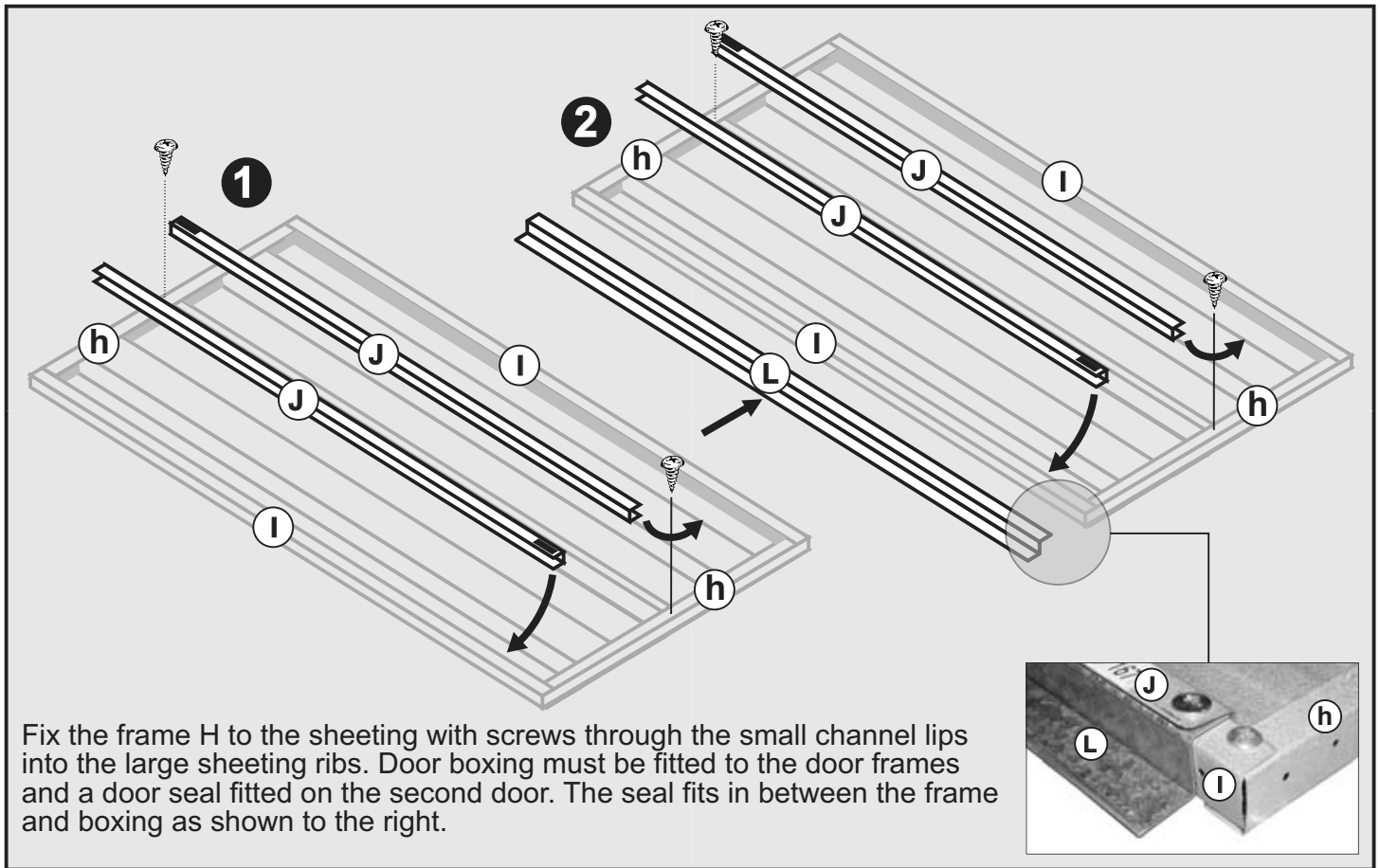

Fix the frame H to the sheeting with screws through the small channel lips into the large sheeting ribs. Door boxing must be fitted to the door frames and a door seal fitted on the second door. The seal fits in between the frame and boxing as shown to the right.

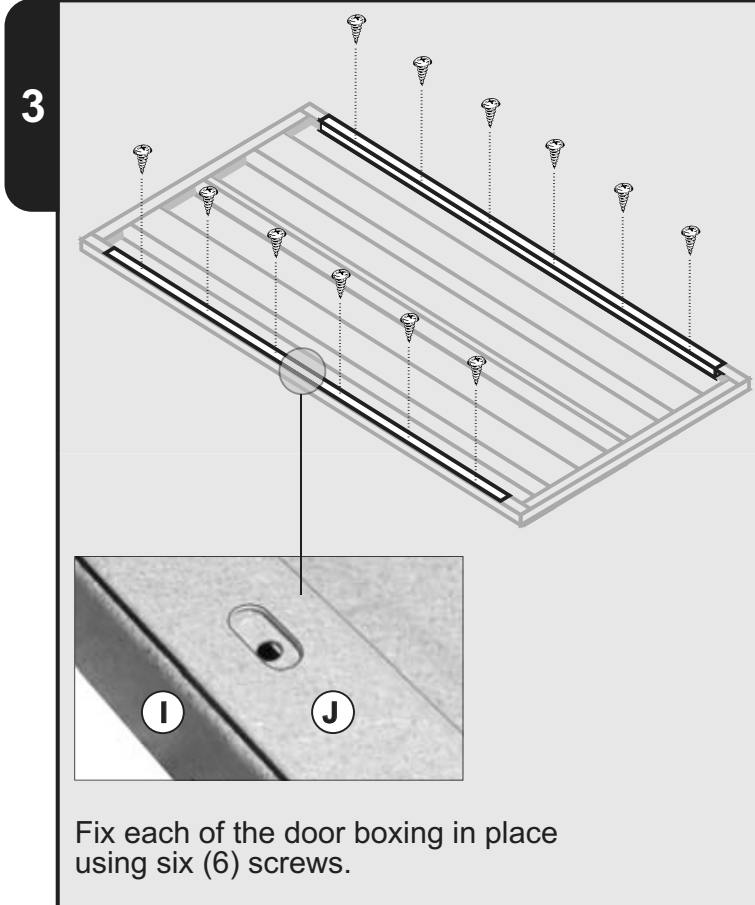

Fix each of the door boxing in place using six (6) screws.

Leave an even gap at both ends of the boxing.

Place large lip of J over the small lip of I as shown

use the pre-punched holes in the door boxing as a guide to drill pilot holes in the door seal

Fix door seal on door number 2

# ASSEMBLE DOOR

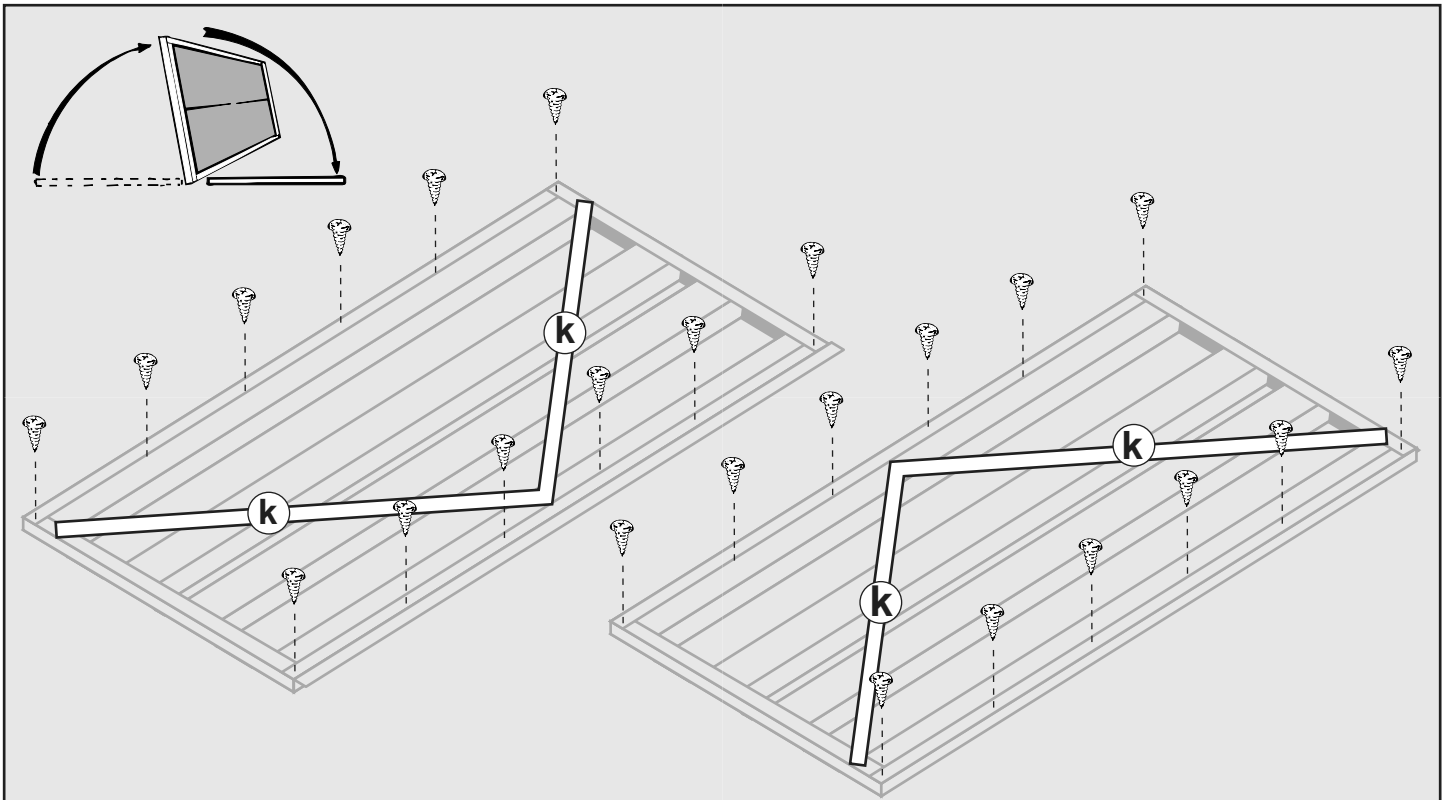

Flip the door assembly's over and fix the door frames with screws evenly spaced as shown above. Door bracing will also need to be fitted to the doors to ensure sturdiness.

4

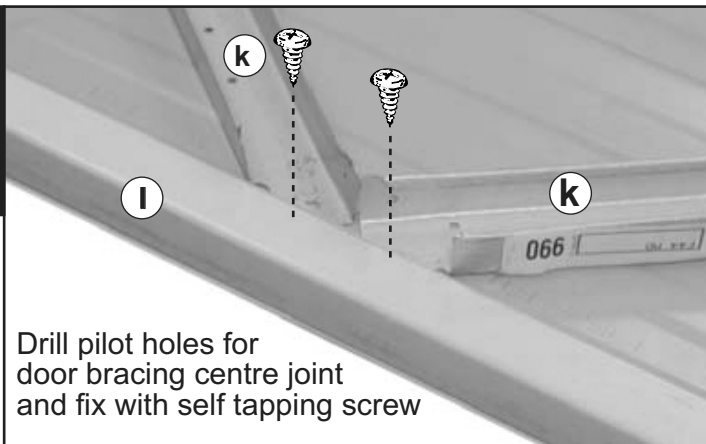

Drill pilot holes for door bracing centre joint and fix with self tapping screw

Drill pilot hole for top and bottom bracing joint, and fix with self tapping screw.

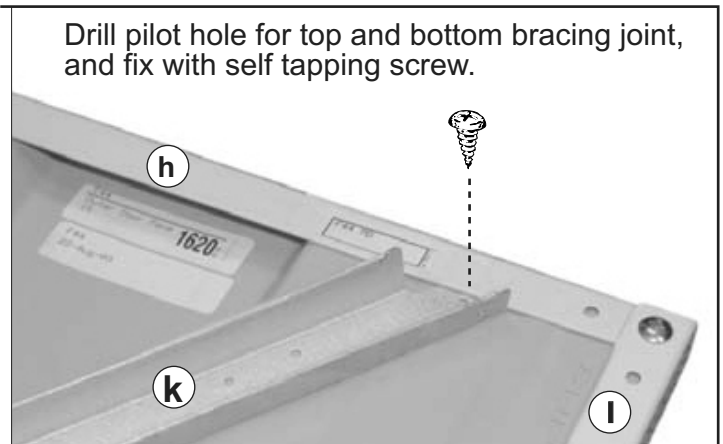

5

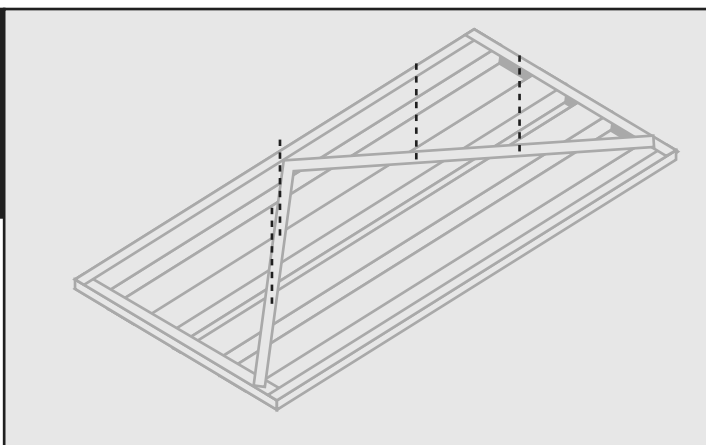

Use the 2.5mm drill bit to drill pilot holes through the door bracing into the door sheeting.

**DO NOT FASTEN BRACING YET**

# ASSEMBLE DOOR

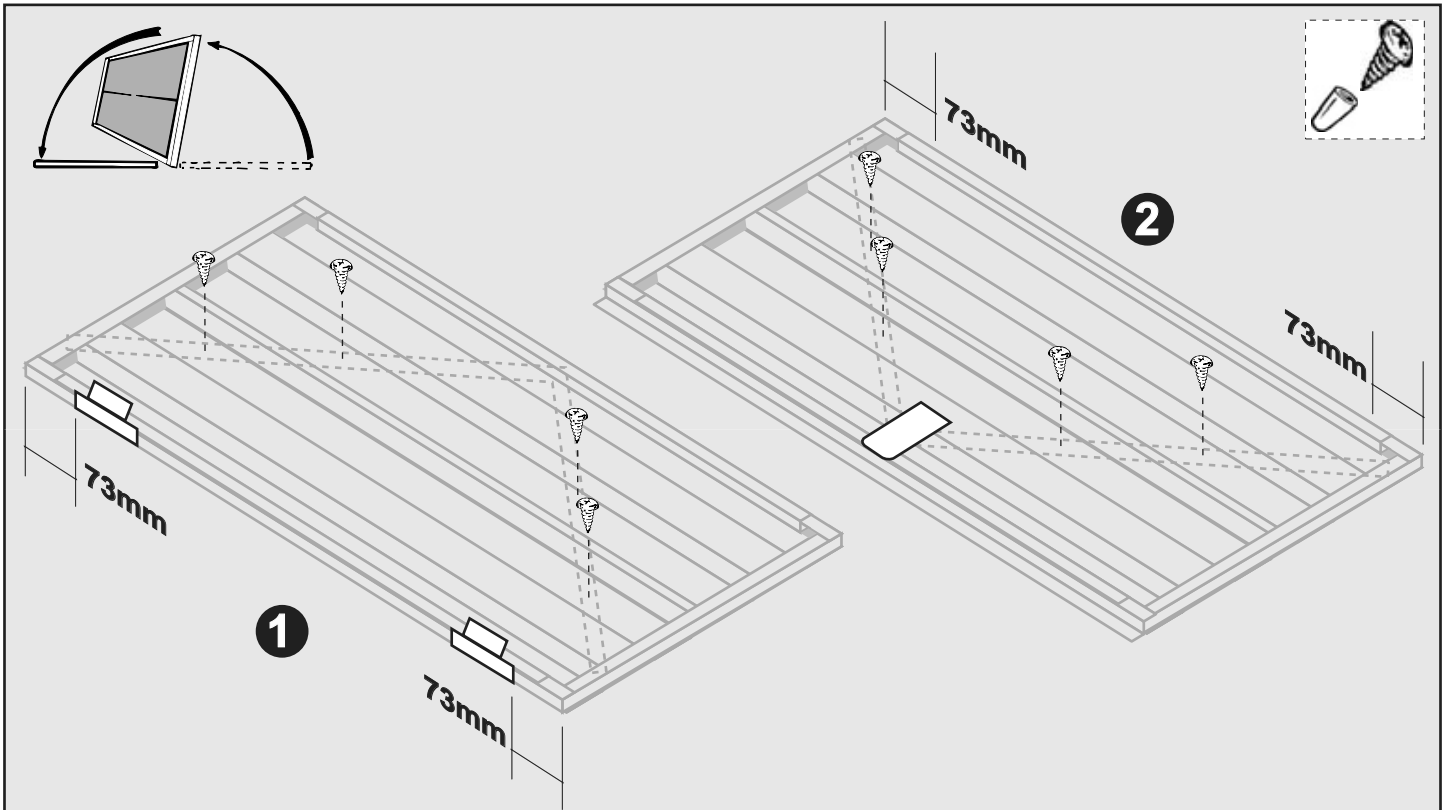

Flip the door back over to the front side facing up. Using the pilot holes drilled before, fix the door bracing from the front with self tapping screws.

6

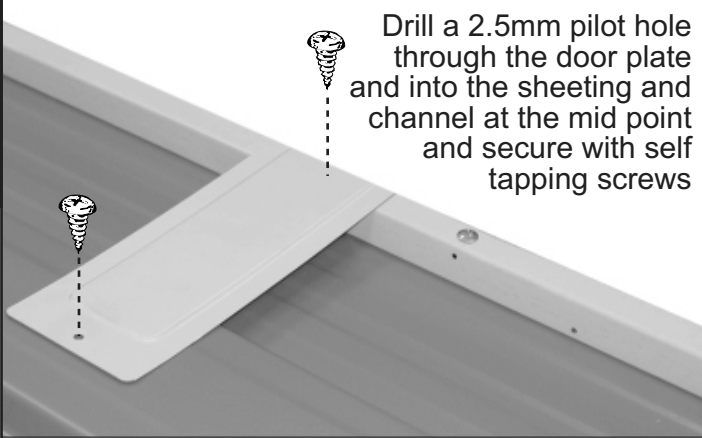

Drill a 2.5mm pilot hole through the door plate and into the sheeting and channel at the mid point and secure with self tapping screws

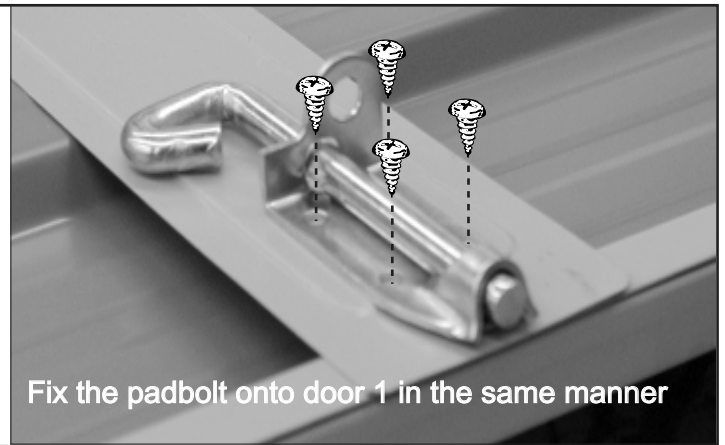

Fix the padbolt onto door 1 in the same manner

7

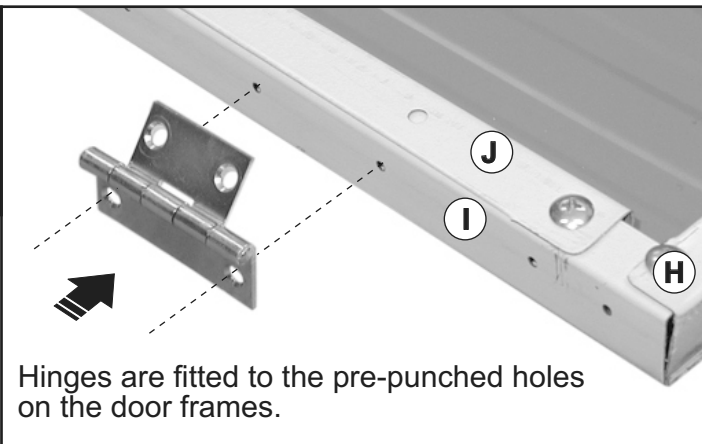

Hinges are fitted to the pre-punched holes on the door frames.

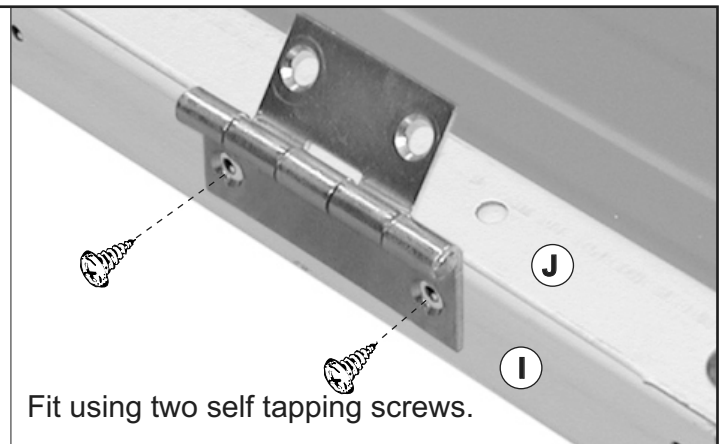

Fit using two self tapping screws.

# HANG DOOR

**NOTE:** The diagram below shows a flat roof shed. The assembly process is the same for all sheds.

Fit the doors by fixing the hinges to the pre-drilled holes in the door jambs. Fit the padbolt and keeper to the front of the doors. To finish, fix padbolts to the inside, top and bottom of the door with the seal attached.

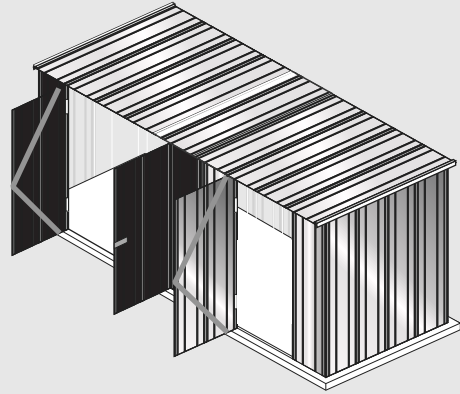

1

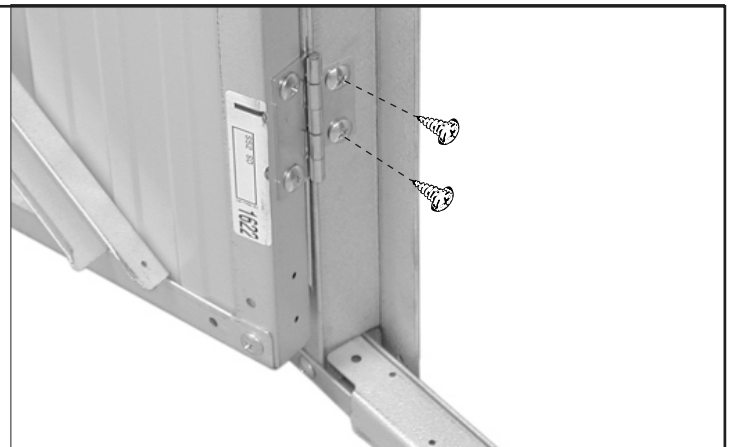

2



Drill pilot holes to accommodate the padbolt keeper and then fix with self tapping screws

3

Drill pilot holes into the inside of the door frame of the second door next to the door seal and then fix with self tapping screws.



Drill pilot holes into the inside of the front wall bottom channel to accommodate the padbolt keeper and then fix with self tapping screws

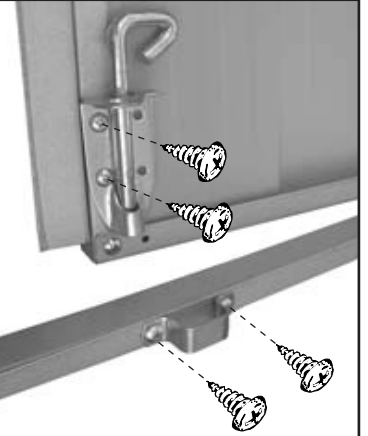

# ASSEMBLE DOOR

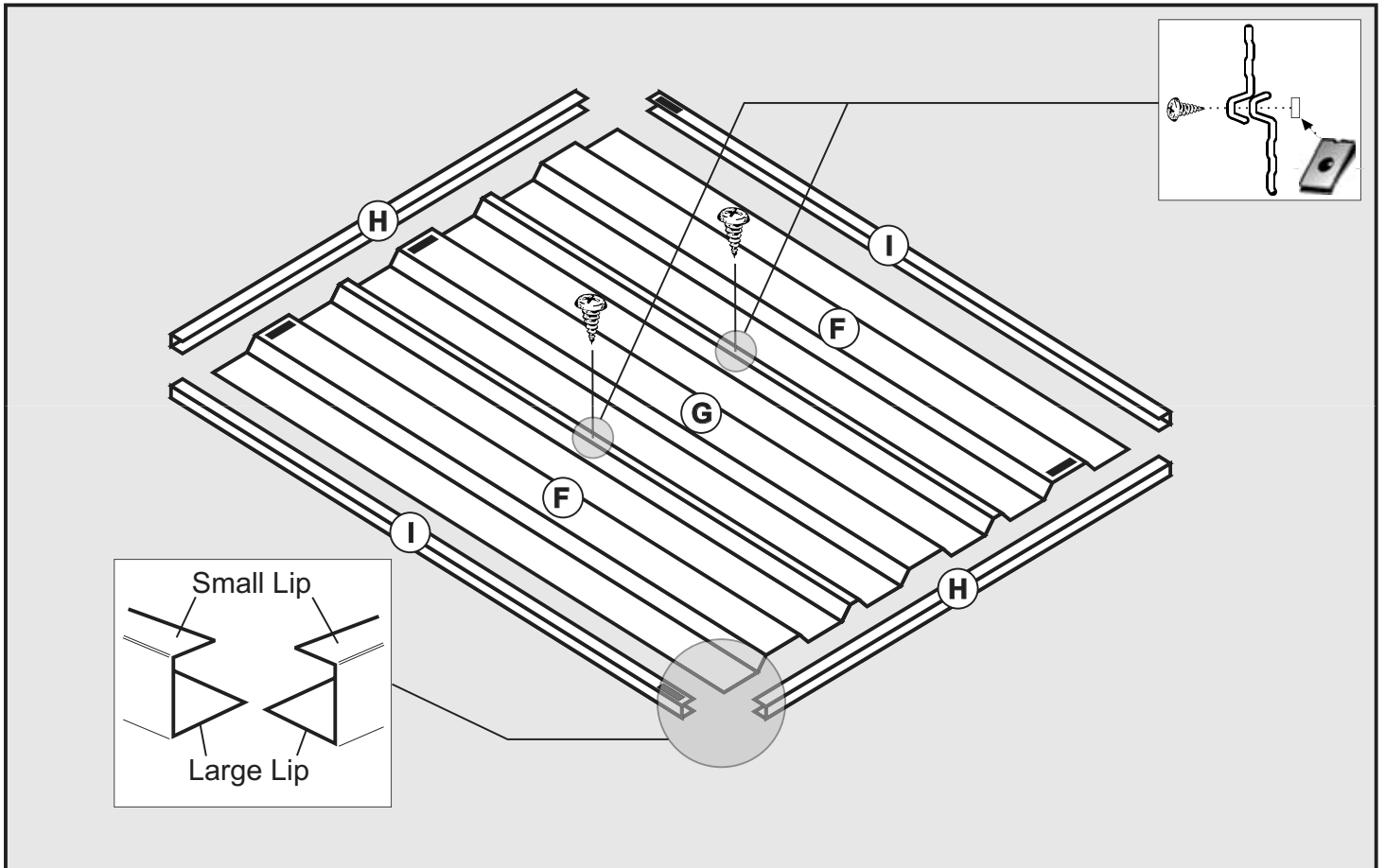

1

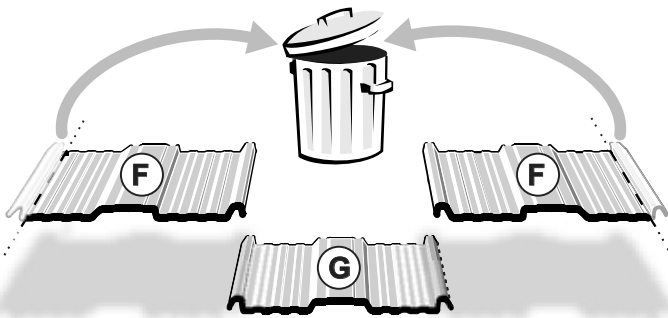

Two of the door sheets come with one rib partially slit. Break them off and discard them.

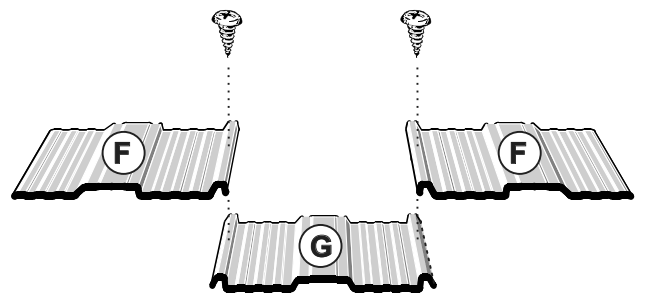

Screw the sheets in the centre.

2

Frames slide under the sheet as shown. Ensure the small lip of the frame is to the top.



Fix door frames with a screw in each corner. Ensure that the big hole sits over the small.



# ASSEMBLE DOOR

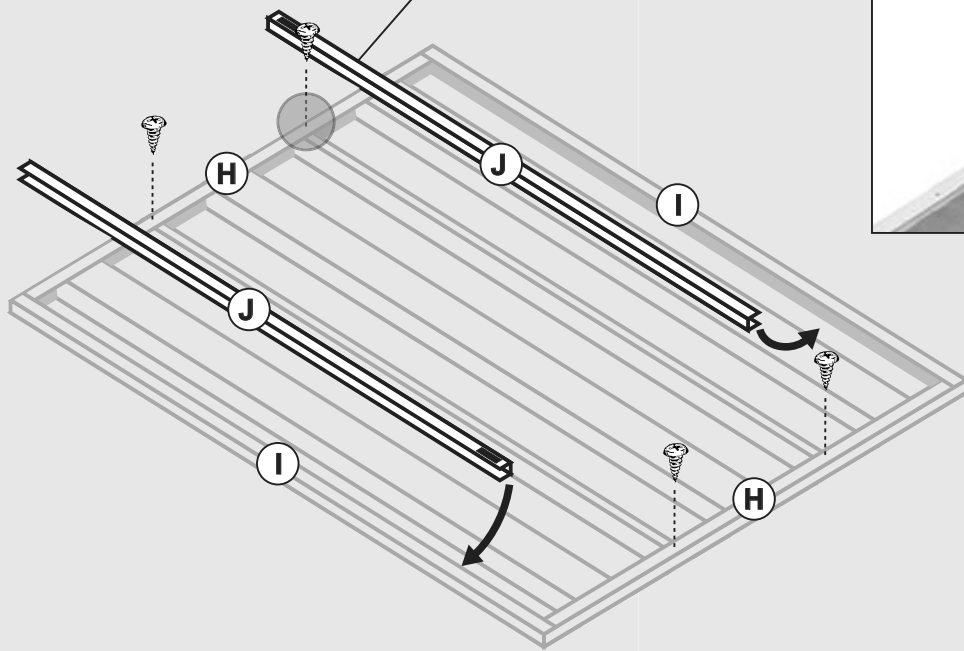

Fix the frame H to the sheeting with screws through the small channel lips into the large sheeting ribs. Door boxing must be fitted to the door frame.

3

Leave an even gap at both ends of the boxing.

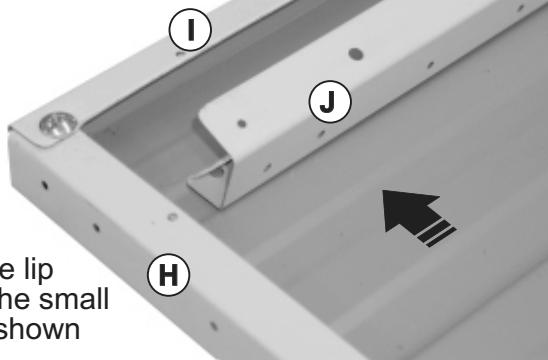

Place large lip of J over the small lip of I as shown

Screw the boxing to the frame as shown to the right

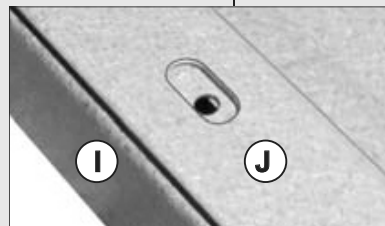
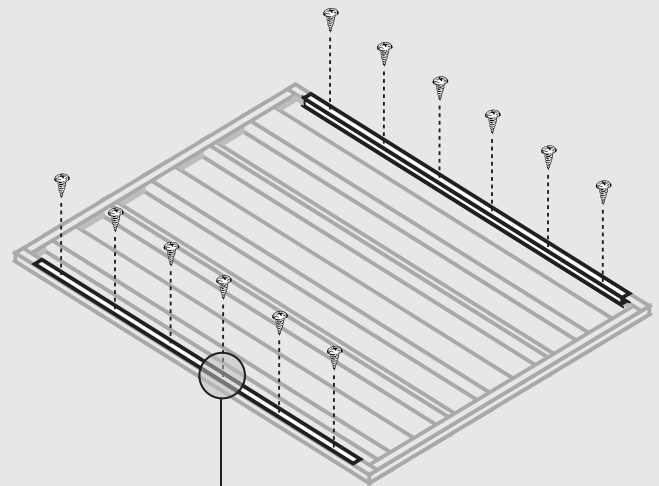
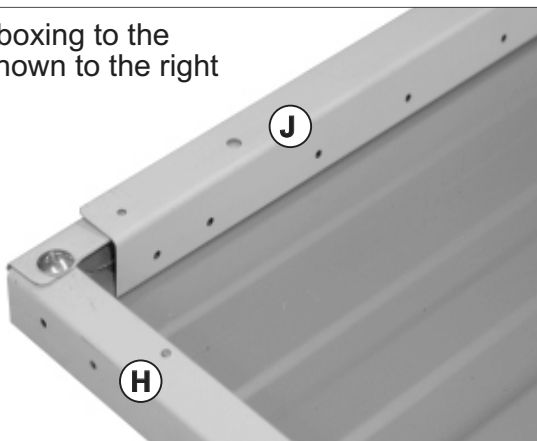

Fix both door boxing in place using six (6) screws.

## ASSEMBLE DOOR

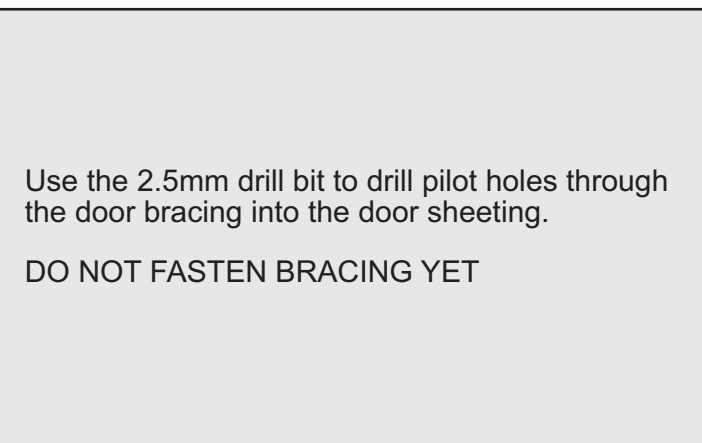
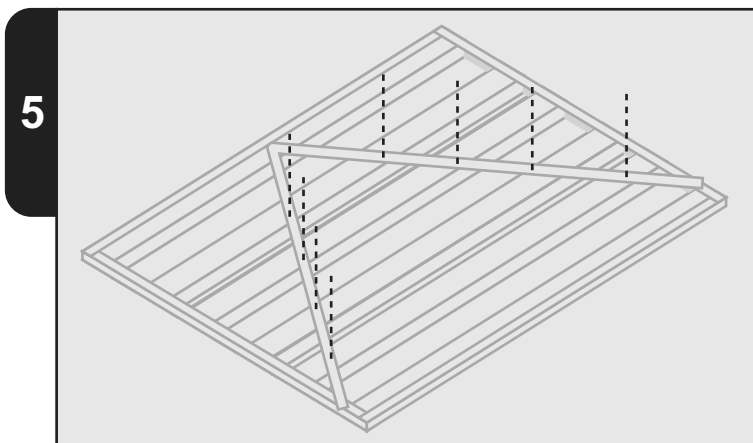
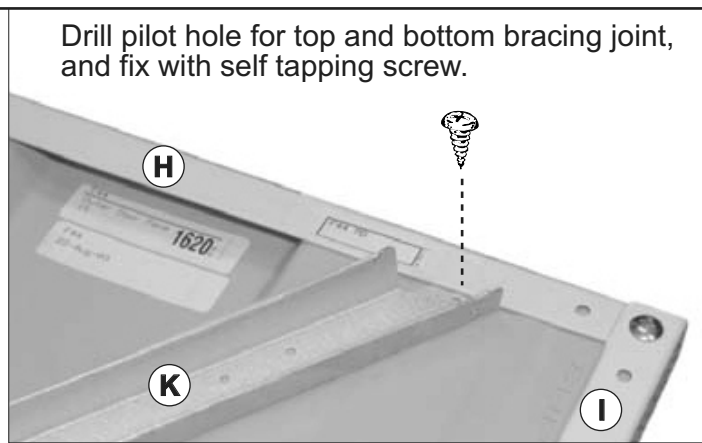
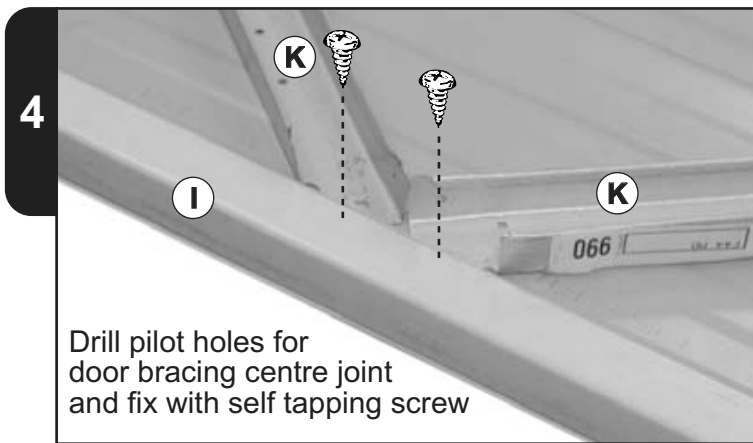
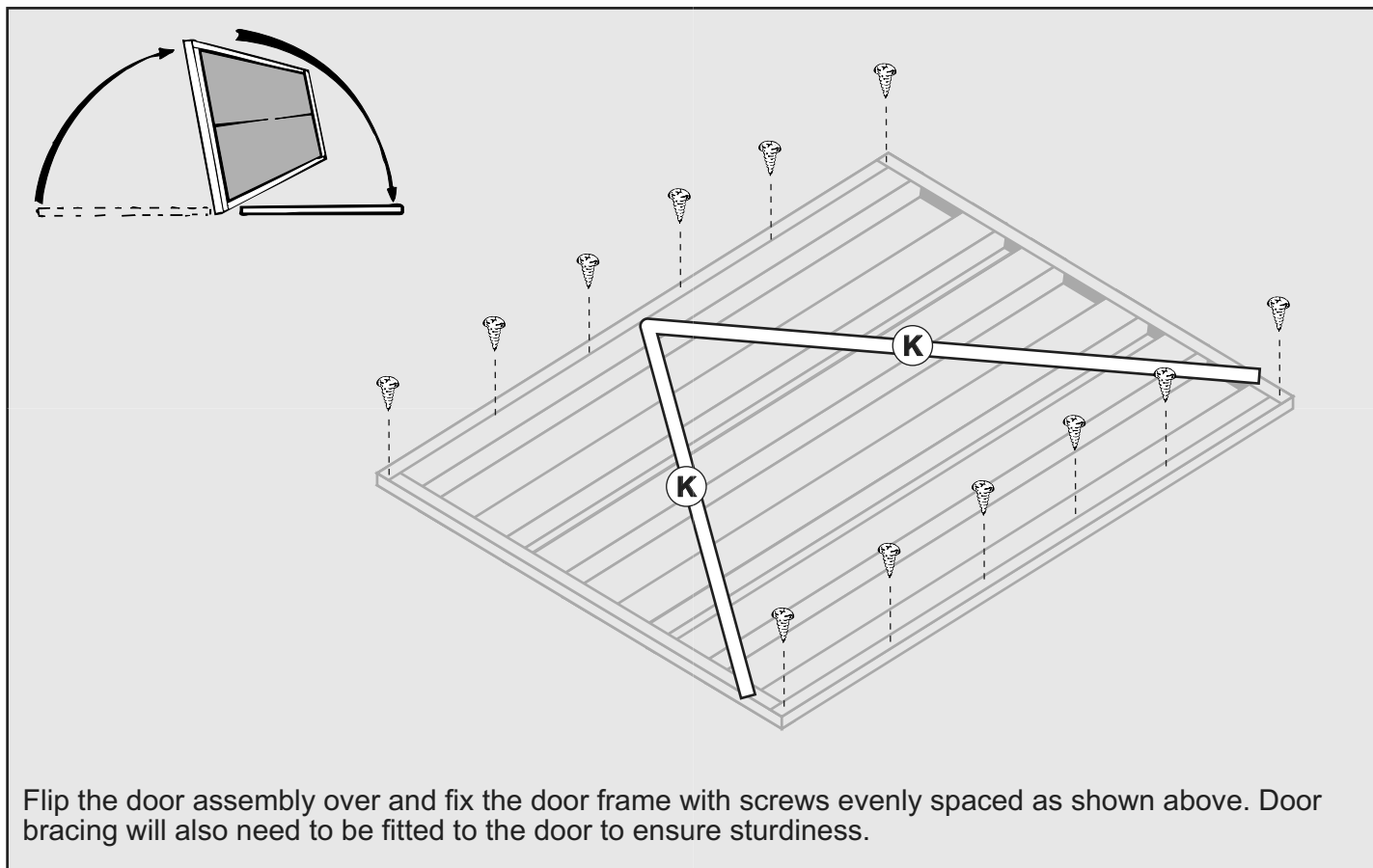

# ASSEMBLE DOOR

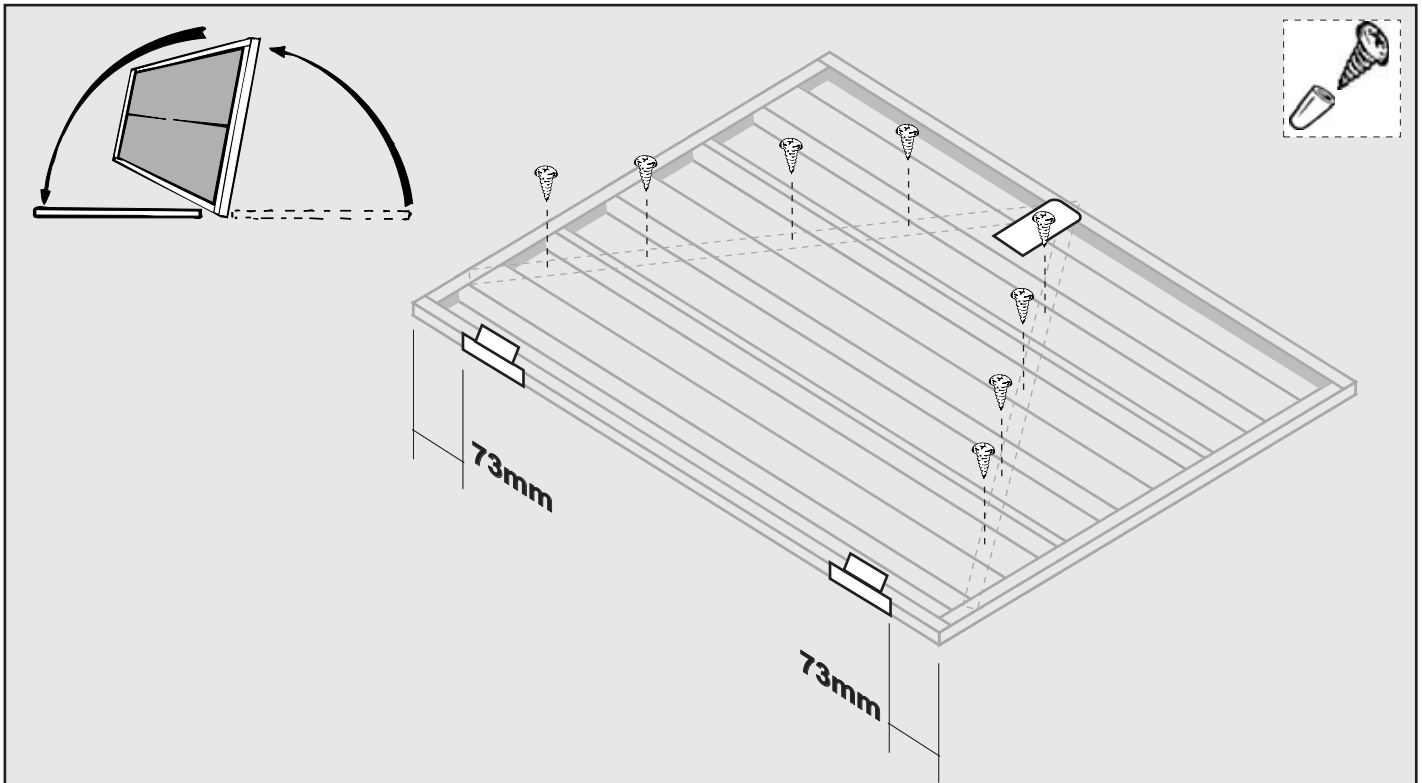

Flip the door back over to the front side facing up. Using the pilot holes drilled before, fix the door bracing from the front with self tapping screws.

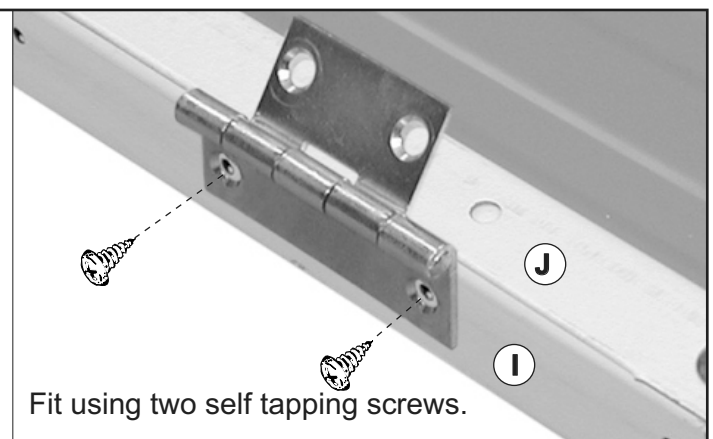
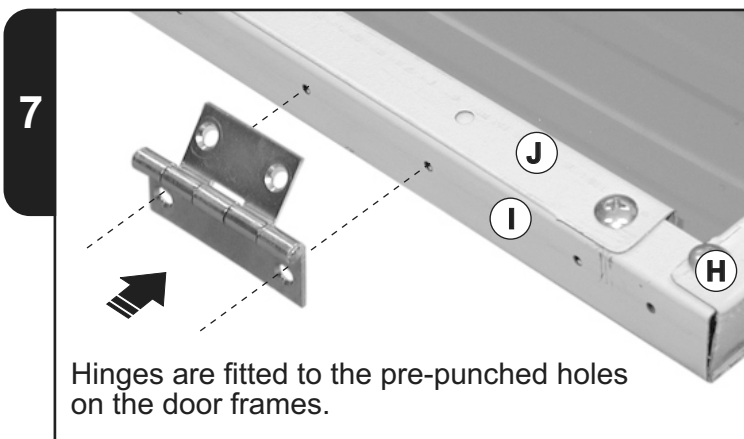
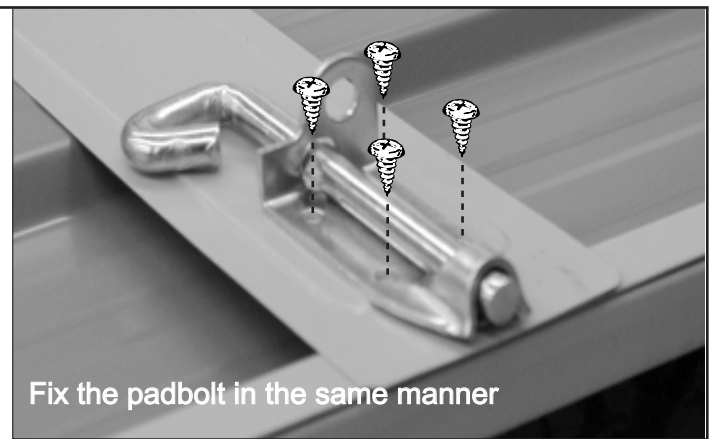
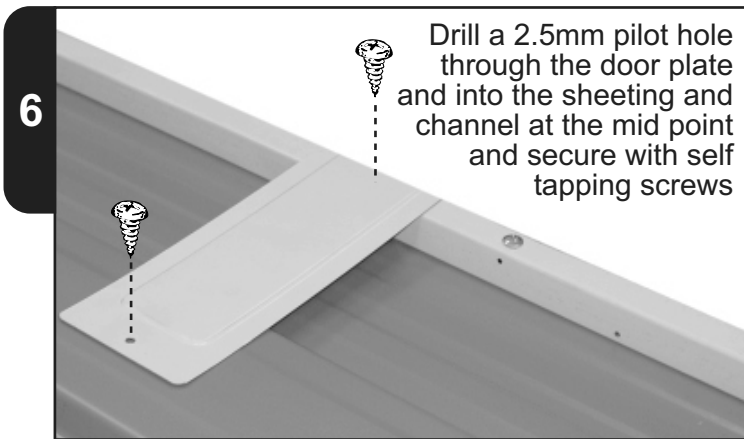

# HANG DOOR

**NOTE:** The diagram below shows a flat roof shed. The assembly process is the same for all sheds.

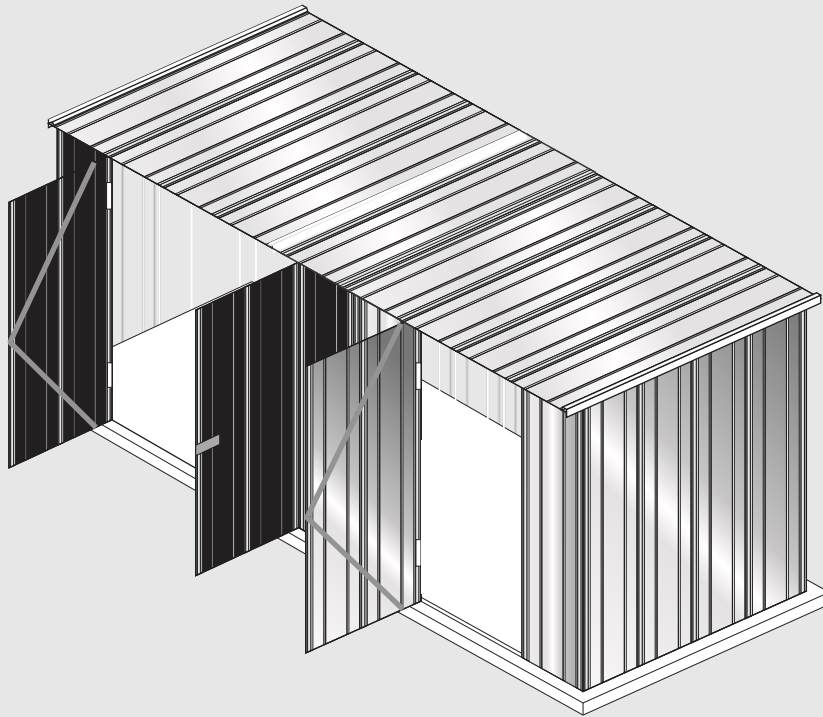

Fit the door to the left or right by fixing the hinges to the pre-drilled holes in the door jambs then fit the padbolt keeper.

1

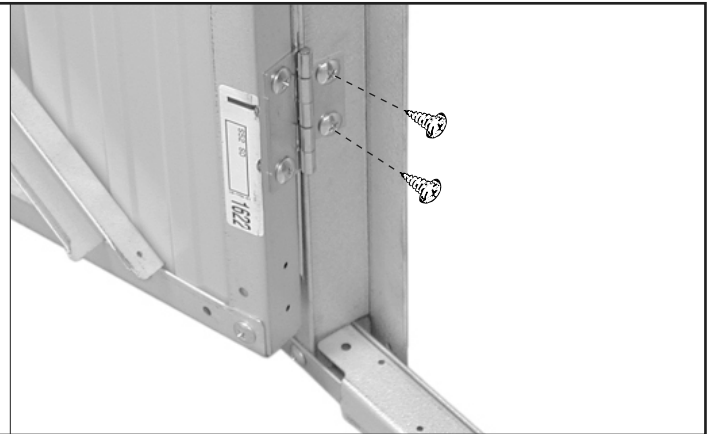

2



Drill pilot holes to accommodate the padbolt keeper and then fix with self tapping screws

## BOLT DOWN



Bolt the shed down through the four corner brackets as shown. Ensure the shed is square.

1

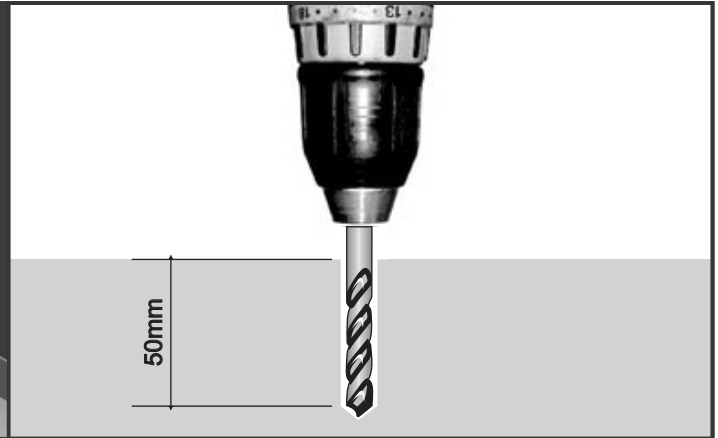
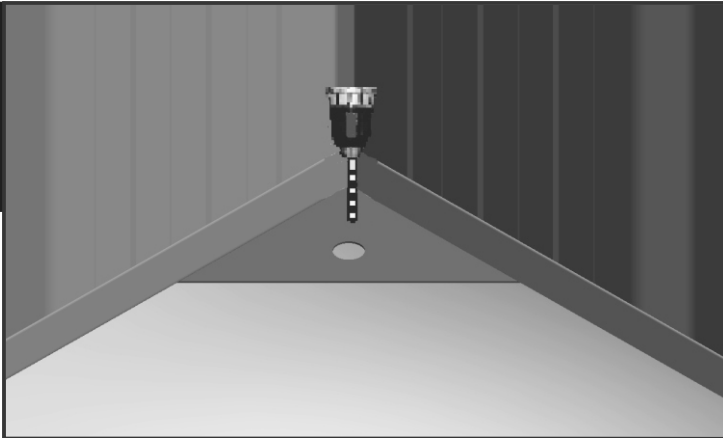

2

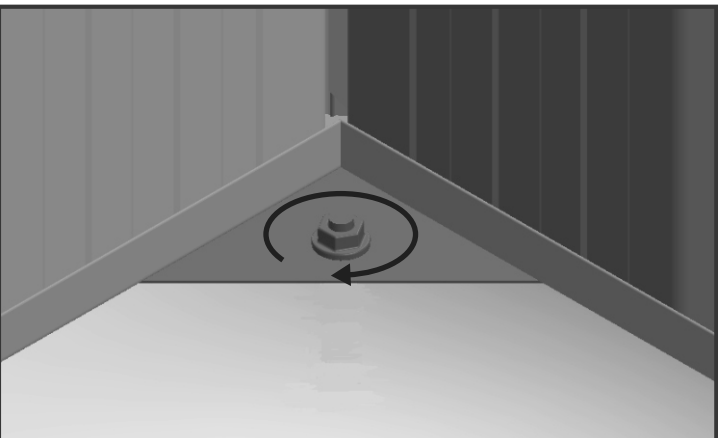
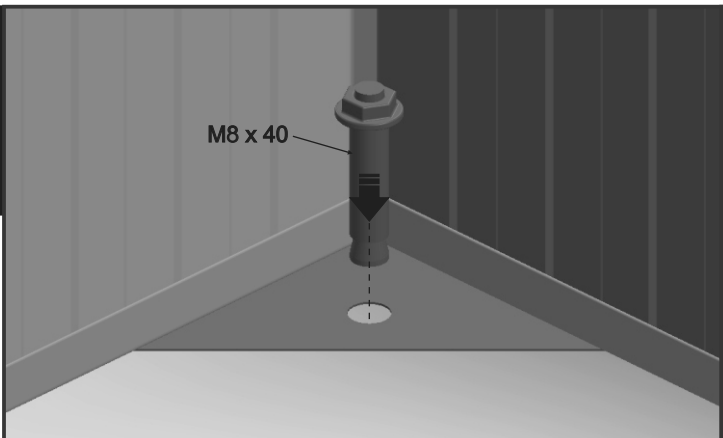

# BOLT DOWN



Bolt the shed down through the angle brackets as shown.

1

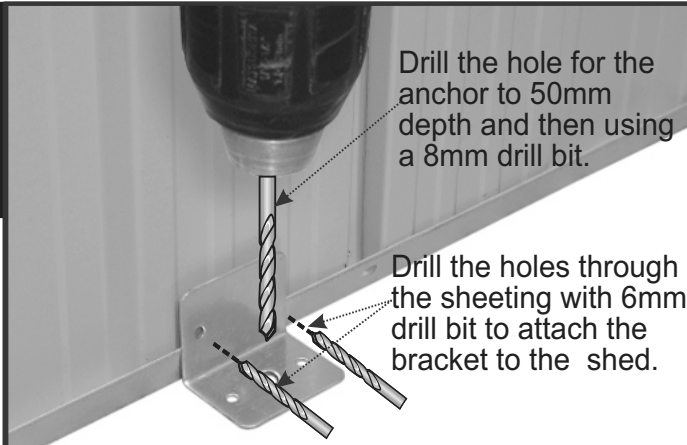

Drill the hole for the anchor to 50mm depth and then using a 8mm drill bit.

Drill the holes through the sheeting with 6mm drill bit to attach the bracket to the shed.

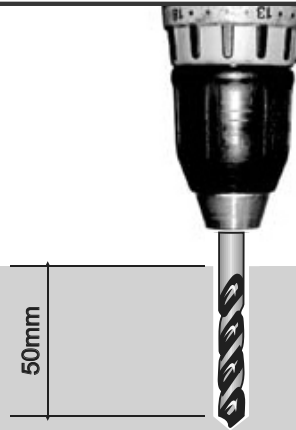

2

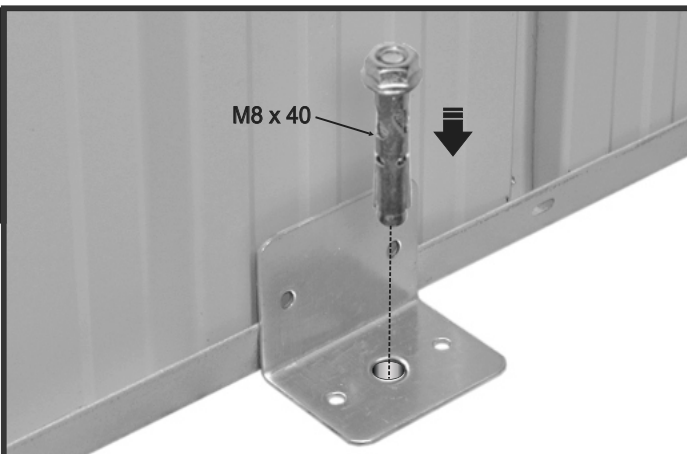

M8 x 40

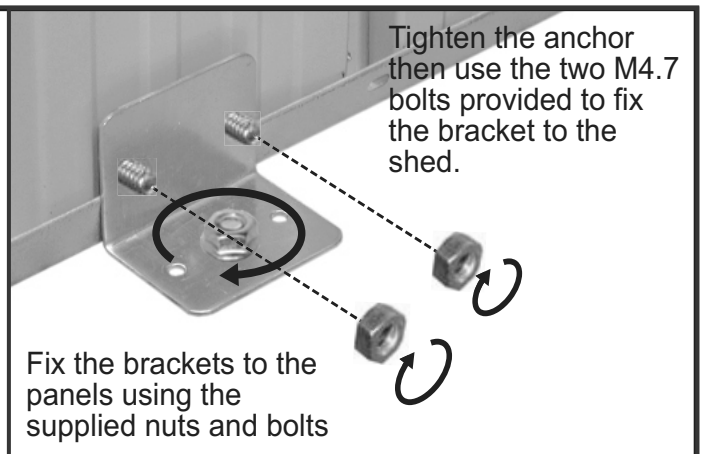

Tighten the anchor then use the two M4.7 bolts provided to fix the bracket to the shed.

Fix the brackets to the panels using the supplied nuts and bolts

# NOTES

## FIT SKYLIGHT (OPTIONAL)

The skylight must be fitted on top of the two adjacent sheets. Fit the steel roof sheets first then fit the skylight as shown below.

1



2

The skylight is fixed using two (2) screws at the top and bottom of the sheet. The inset shows a closeup of the overlap. Pilot holes will need to be drilled

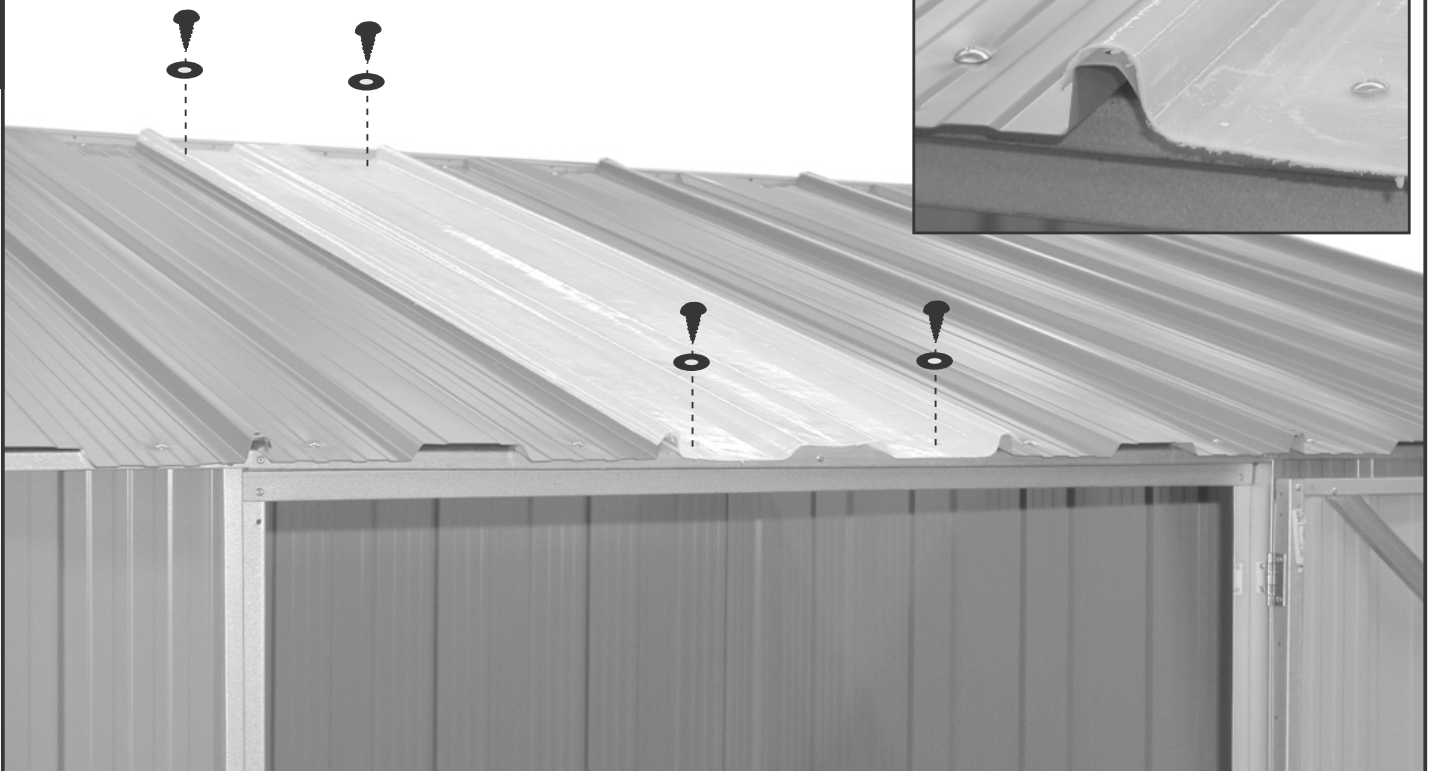
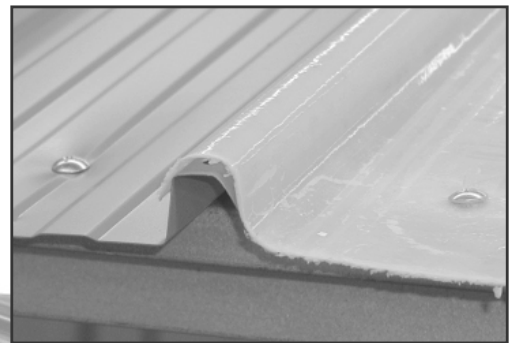



Simple, Strong,  
Quick & Easy

# 15 Years Warranty

Thank you for purchasing FASTTRAK® system steel storage shed.

Your personal warranty is backed by Spanbilt®, the manufacturer of FASTTRAK® system storage sheds, and our proven commitment to quality and customer service. Our goods come with guarantees that cannot be excluded under Australian consumer law. You are entitled to a replacement or refund of a major failure and compensation for any reasonably foreseeable loss or damage. You are also entitled to have the goods repaired or replaced if the goods fail to be of acceptable quality and the failure does not amount to a major failure. Cost of claiming the warranty will be borne by the claimant. This warranty is in addition to other rights and remedies of the customer under law.

## Eligibility

- The 15 year warranty is eligible only to the original purchaser/owner of the shed as registered within 60 days from the date of purchase and is not transferrable.
- The warranty is valid for both Australia & New Zealand
- The warranty is subject to location and local environmental conditions outlined in the warranty exclusions below.

## What is covered under the warranty?

FASTTRAK® steel storage shed 15 year warranty is limited to the following specific cover.

1. Zinc and/or galvanised panel materials will not rust
2. Coloured panel materials will not rust, flake, peel or blister.

Please note the 15 year warranty does not apply to any accessory items such as fasteners, Hasp, Pad bolts, also including flooring kits, shelving, hook sets, tool racks etc.

## Warranty Qualifications & Limitations

The FASTTRAK® 15 year warranty is subject to the following qualifications and limitations

1. Warranty does not apply to surface deterioration of the panels caused specifically by
  - a) "Swarf" (tiny particles of steel debris left from cutting, grinding or drilling operations) that have not been dutifully removed during the assembly construction process.
  - b) As a result of contact with damp soil, chemicals, fertilisers, or other corrosive substances
2. Warranty does not cover damage caused by storms, wind, rain, hail, snow or any other adverse environmental event or "act of god"
3. Warranty only applies if the shed is used solely for domestic purposes and installation is in accordance and compliance with the FASTTRAK® instruction manual and manufacturer recommendations.
4. Warranty does not apply if the shed is installed / located in
  - a) Ocean/surf locations (typically defined as within 1km from coastal or tidal locations),
  - b) Severe industrial locations
  - c) Unusually corrosive environments (e.g. Geothermal / Sulphuric conditions)
5. Warranty does not cover any damage as a result of
  - a) Any impact
  - b) Due to poor foundations
  - c) Modifications
  - d) Build-up of debris on or in roof or walls
  - e) Poor assembly and/or construction Build-up of debris on or in roof or walls
6. The warranty will be void if the shed has been relocated from its original location / address.
7. The warranty is limited to the replacement and delivery of panels and specifically excludes any labour, installation or removal/disposal costs.
8. Warranty applies to the exclusions of all other representations, guarantees or warranties, either expressed or implied unless otherwise required by applicable legislation.
9. Your warranty registration certificate and supporting documentation must be completed and lodged within 60 days of the date of purchase.

## Warranty Claims

All warranty claims should be made in writing sent directly to:

### Australia

Spanbilt  
PO Box 1581,  
Browns Plains, Queensland, 4118

### New Zealand

Spanbilt  
PO Box 11-013,  
Sockburn, Christchurch 8443

Claims must include:

- a) Original proof of purchase documentation
- b) Relevant contact information
- c) Product model
- d) Photographic evidence
- e) Description of the damage



**Simple, Strong,  
Quick & Easy.**

## Warranty Registration Certificate

### Owners Details

Owners Name:

Street Address:

City:

Postcode:

Email:

### Building Details

Product Model Number:

Colour:

Place of Purchase:

Purchase Date:

Please attach here a photocopy of proof of purchase

Retain the original for your records

You must submit your warranty registration certificate within 60 days of the purchase date of your FASTTRAK® garden shed.

Post your certificate and supporting documentation to:

#### **Australia**

Spanbilt

PO Box 1581, Browns Plains

Queensland, 4118

#### **New Zealand**

Spanbilt

PO Box -11013,

Sockburn, Christchurch 8443

# **FASTTRAK**

**Simple, Strong,  
Quick & Easy.**

**PO Box 1581  
Browns Plains, QLD 4118**

**Enquiries  
07 3827 8000  
Fax  
1800 222 166**

**Building Advice Line  
1800 032 077  
[www.spanbilt.com.au](http://www.spanbilt.com.au)**

---

**112 Waterloo Road  
PO Box 11 -013  
Sockburn, Christchurch**

**TELEPHONE  
03 349 3480  
Fax  
0800 772 6245  
[www.spanbilt.co.nz](http://www.spanbilt.co.nz)**

**Another Quality Product From**

